

SINGOLO 4836

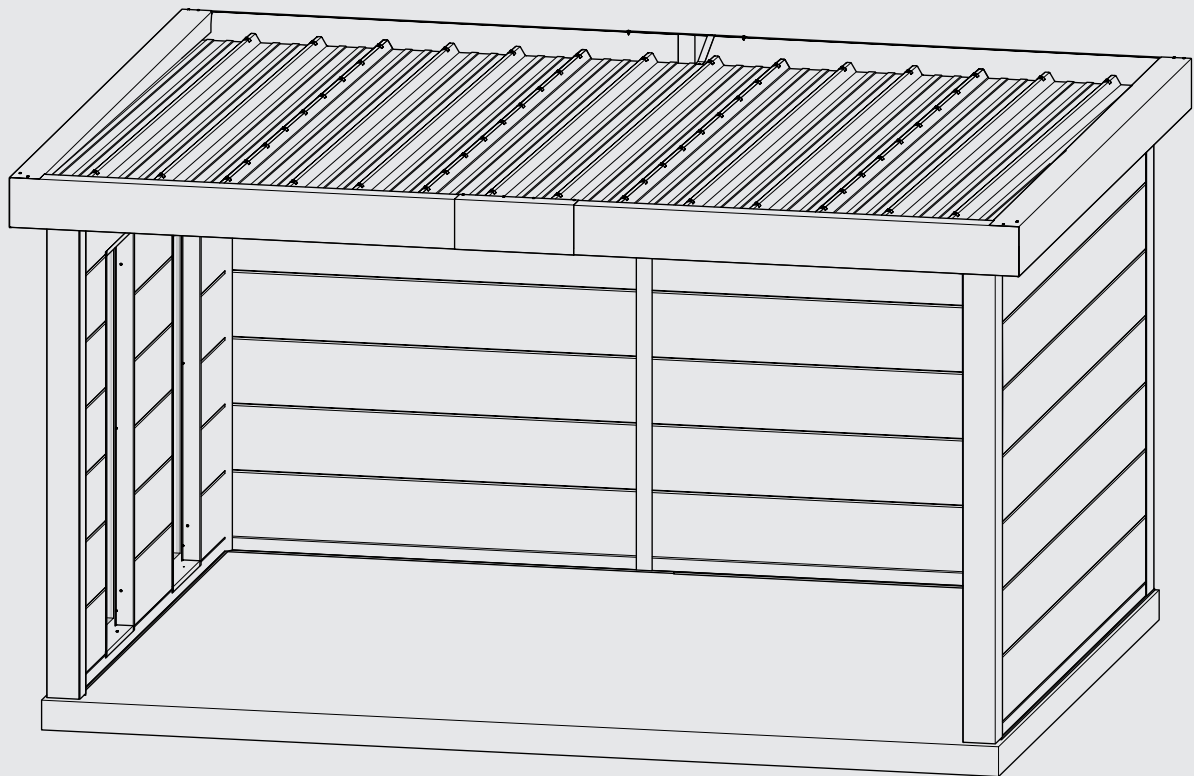

Projet numéro / Project nummer / Project number / Projekt Nummer :

.....

QC-numéro / QC-nummer / QC-number / QC-Nummer :

.....

Couleur / Kleur / Colour / Farbe:

Blanc, Wit, White, Weiß

Gris clair, Licht grijs, Light grey, Lichtgrau

Anthracite, Antraciet, Anthracite, Granitgrau

INSTRUCTIONS DE MONTAGE
MONTAGE HANDLEIDING
ASSEMBLY INSTRUCTIONS
MONTAGEANLEITUNG

telluria

LET US STEEL YOUR HEART

Nous vous invitons à lire attentivement le présent mode d'emploi. Vous y trouverez les caractéristiques techniques ainsi que toutes les informations utiles en vue d'un fonctionnement correct. Les données techniques figurant dans cette publication peuvent être modifiées à tout moment et sans avis préalable et ce, pour des raisons techniques ou commerciales..

Wij nodigen u uit deze handleiding aandachtig te lezen. Ze omvat de technische eigenschappen en alle nuttige informatie voor een correcte werking. De technische gegevens in deze publicatie kunnen om technische of commerciële redenen op elk moment en zonder voorafgaande kennisgeving worden gewijzigd.

Please read this manual carefully. It contains the technical properties and all the information required for correct operation. The technical data in this publication is subject to change for technical and/or commercial reasons at any time and without notice.

Bitte lesen Sie diese Anleitung sorgfältig durch. Sie enthält die technischen Eigenschaften und alle Informationen, die für einen korrekten Betrieb erforderlich sind. Die in dieser Publikation enthaltenen technischen Daten können jederzeit ohne Vorankündigung aus technischen oder kommerziellen Gründen geändert werden.

						
Lisez bien l'ensemble du mode d'emploi avant de commencer à réaliser des travaux.	L'utilisation de gants est obligatoire.	L'utilisation de lunettes de protection est obligatoire.	L'utilisation d'un casque de protection est obligatoire.	L'utilisation d'une meule est interdite	Déballage à 2 personnes	Retirer les éclats de métal.
Lees de volledige handleiding voordat u begint met de werken uit te voeren.	Het gebruik van handschoenen is verplicht.	Het gebruik van een veiligheidsbril is verplicht.	Het gebruik van een veiligheidshelm is verplicht.	Het gebruik van een slijpschijf is verboden	Met 2 personen uitpakken	Metaalsplinters verwijderen
Read the entire manual before you start working.	The use of gloves is mandatory.	The use of safety glasses is mandatory.	The use of a hard hat is mandatory.	The use of an angle grinder is prohibited	Unpack with 2 people	Cleaning up metal splinters
Lesen Sie vor Arbeitsbeginn die gesamte Anleitung.	Das Tragen von Handschuhen ist Pflicht.	Das Tragen einer Sicherheitsbrille ist Pflicht.	Das Tragen eines Sicherheitshelms ist Pflicht.	Die Verwendung einer Schleifscheibe ist verboten	Auspacken mit 2 Personen	Metallsplinter entfernen

Liste d'outils / Gereedschappenlijst / Tools List / Werkzeugliste

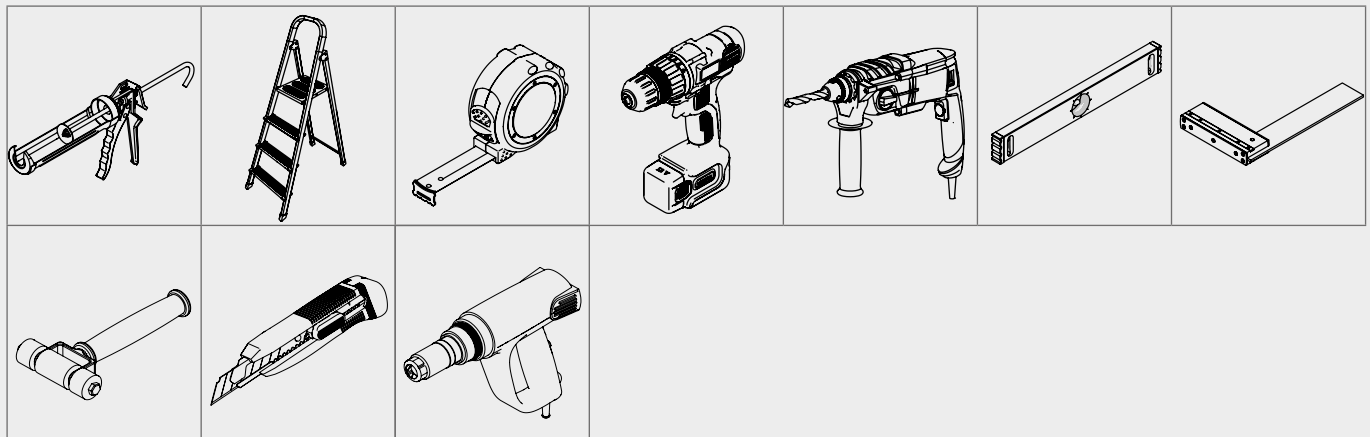

Liste des composants / Stukslijst / Partslist / Teileliste

Pour la liste actuelle des pièces, voir pièce jointe.
 Voor de actuele stuklijst zie bijlage.
 For the current parts list see attachment.
 Aktuelle Stückliste siehe Anhang.

Eleganto Lounge Small / 3024 / Anthracite / Right						
EP.GRT.ANT.3024PHR						21569.1
KIST.04 x1	S.3024PHR x1	BE x33	FE x10	SSP x1	WP45 x1	SDPH x2
FD18 x1	FPN2 x2	FPN1 x1	JDA27 x2	JZ7 x2	JDA27 x1	JZ7R x1
J21 x3	J21S x3	W2 x1	WD18 x1	SDA21 x11	SDA21V x1	
SDA45 x6	S.ZAV-ZCVR x1	HPH x1	SH45 x4	S.ZZ18D x1	S.ZZ18A x1	S.ZZ18C x1
SDPH x1	SPH x2	SPH x1	SDPH x1	SDPH x1	SPPH x1	SAS x1
S.ZPH x1	A21 x3	AD27 x1	A27 x2	M21 x3	M27 x3	D.BS x1
S.AP x1	SE x2	SD x1	SDS1 x1			

Fundament

- Le sol doit être plat et de niveau. Le sol doit être réalisé pour permettre une fixation adéquate de l'abris de jardin.
- De vloer moet vlak en waterpas zijn. De vloer moet gemaakt worden zodat de bevestiging van het tuinhuis wel mogelijk is.
- The floor must be flat and level. The floor must be made in such a way that it is possible to fix the garden house.
- Der Aufbauort muss eine flache, geschlossene und in Waage liegende Bodenplatte aufzeigen. Die Bodenplatte muss so beschaffen sein, das eine mechanische Befestigung von dem CLASSICO erfolgen kann.

PS

- L'abris de jardin doit être centrée sur la dalle de béton.
- Het tuinhuis moet gecentreerd geplaatst worden op het fundament.
- The garden house must be centered on the foundation.
- Das Gartenhaus muss auf dem Fundament zentriert sein.

Tous les éléments / Alle elementen / All elements / Alle Elemente

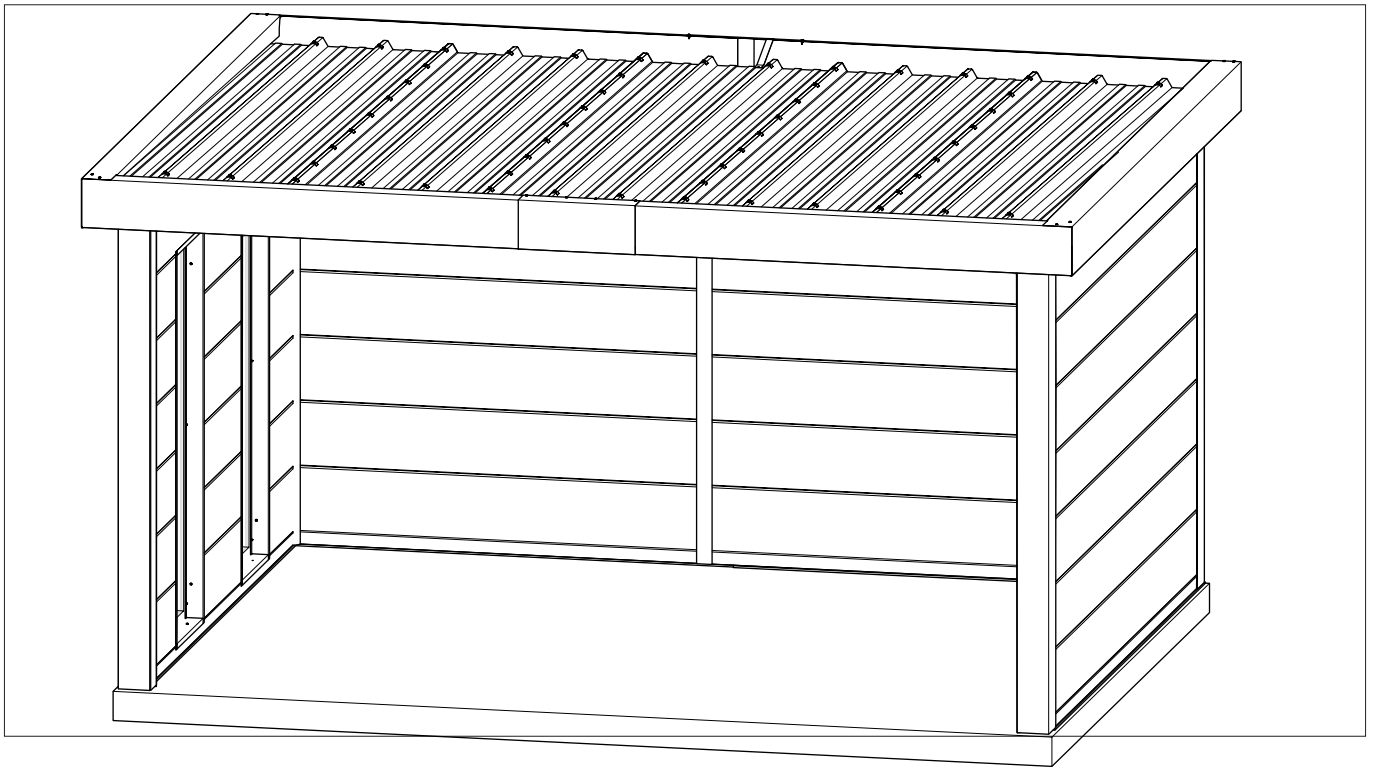

Composition / Compositie / Composition / Zusammensetzung

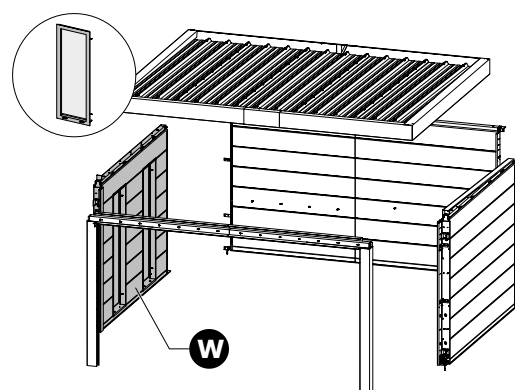
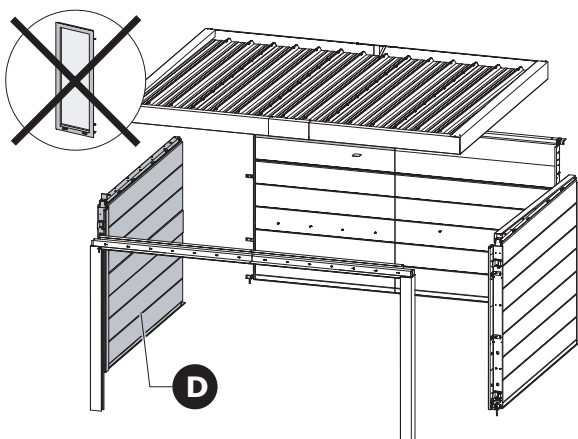
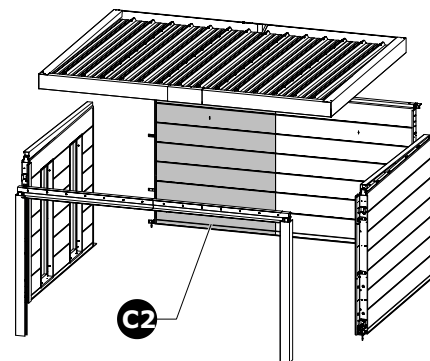
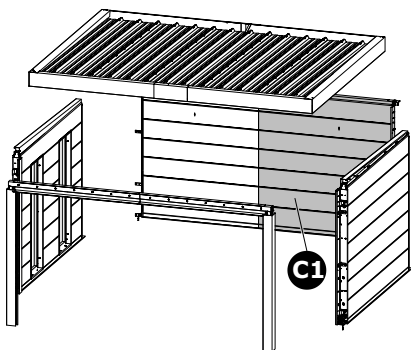
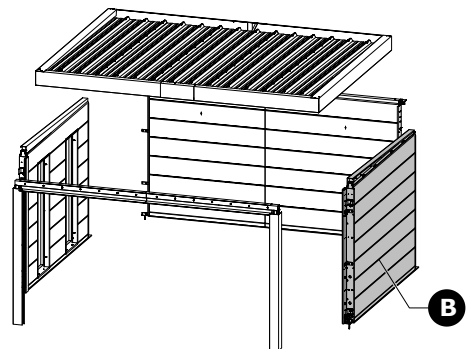
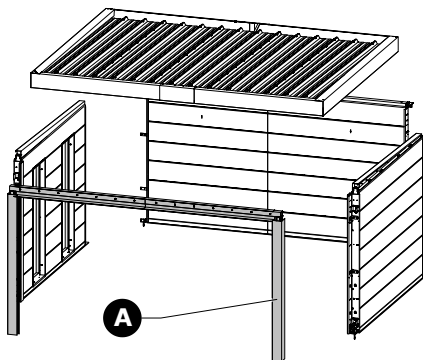
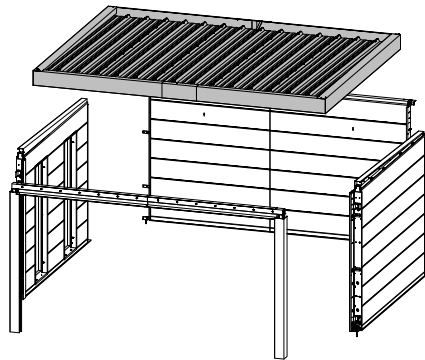

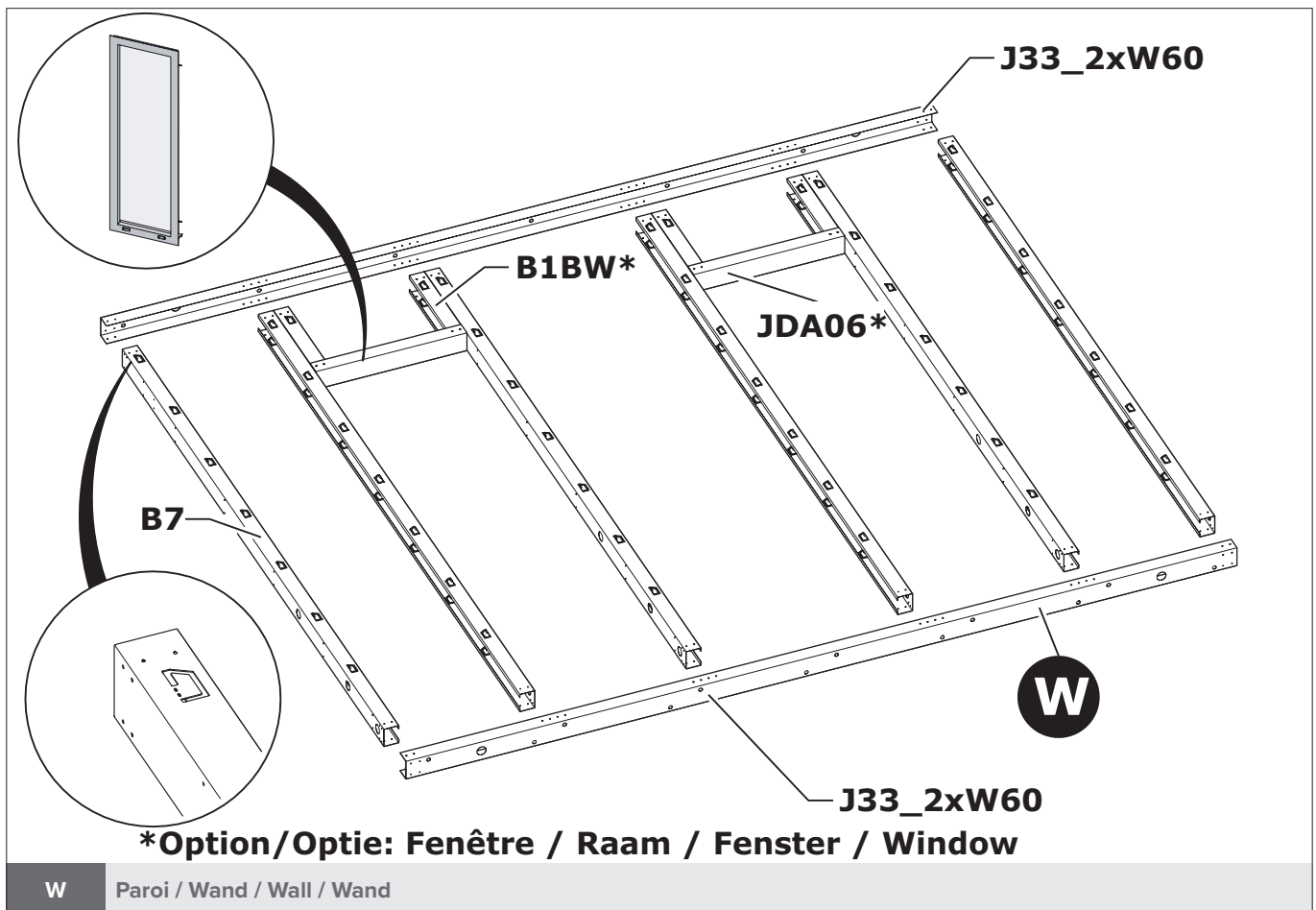
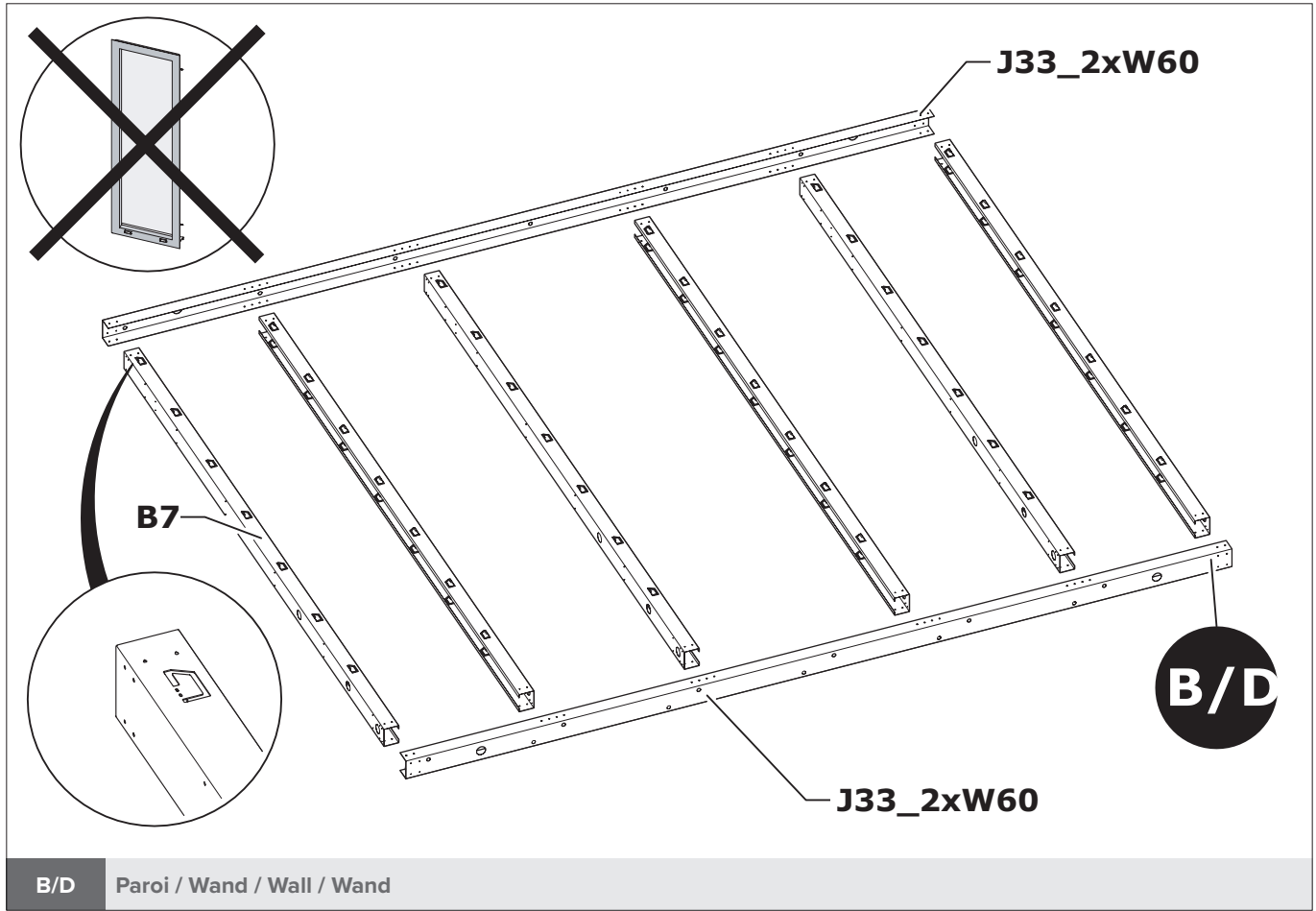

Le principe de la construction du mur (POW).
Het principe van de opbouw van de wand (POW).
The principle of building the wall (POW).
Aufbau der wandelemente (POW).

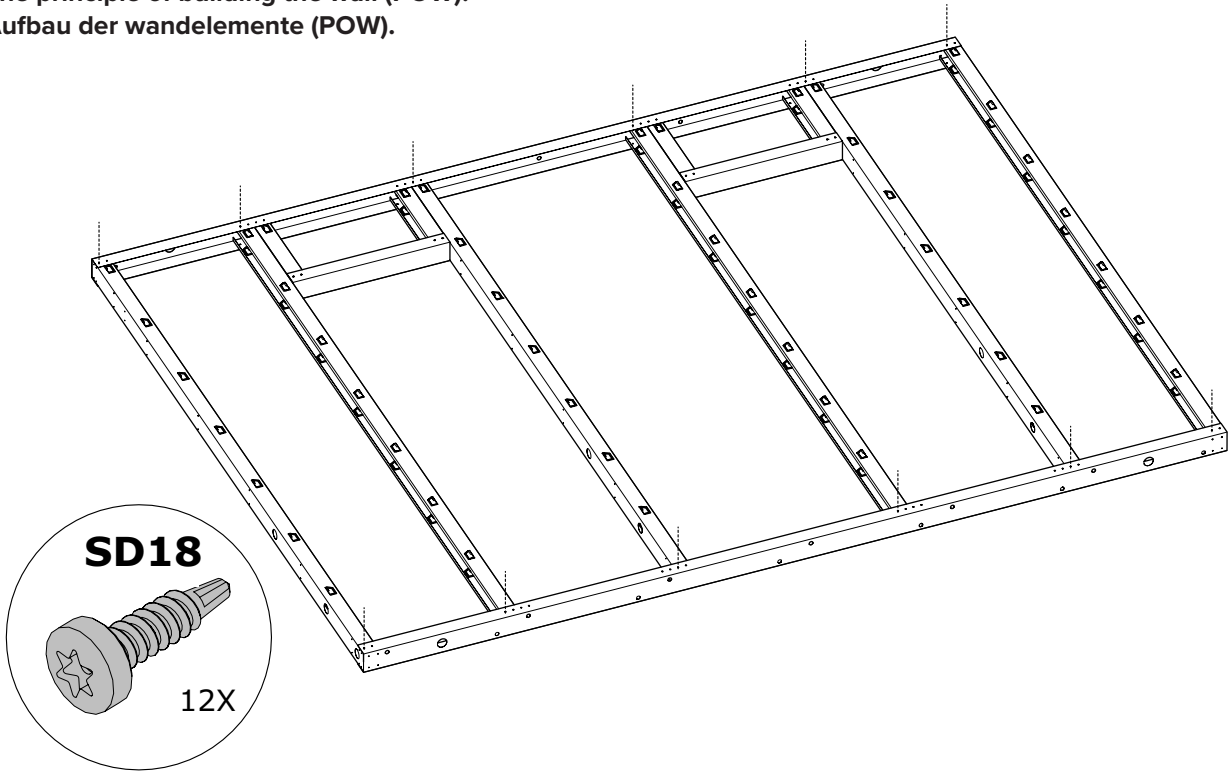

B/D/W Paroi / Wand / Wall / Wand

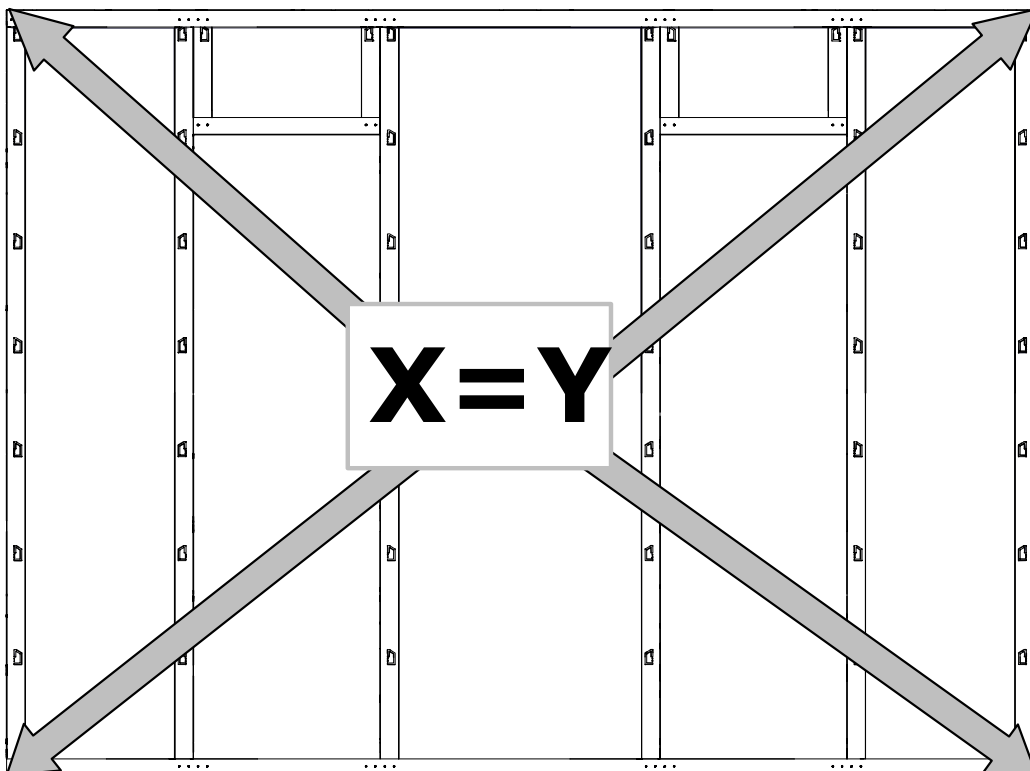

B/D/W Paroi / Wand / Wall / Wand

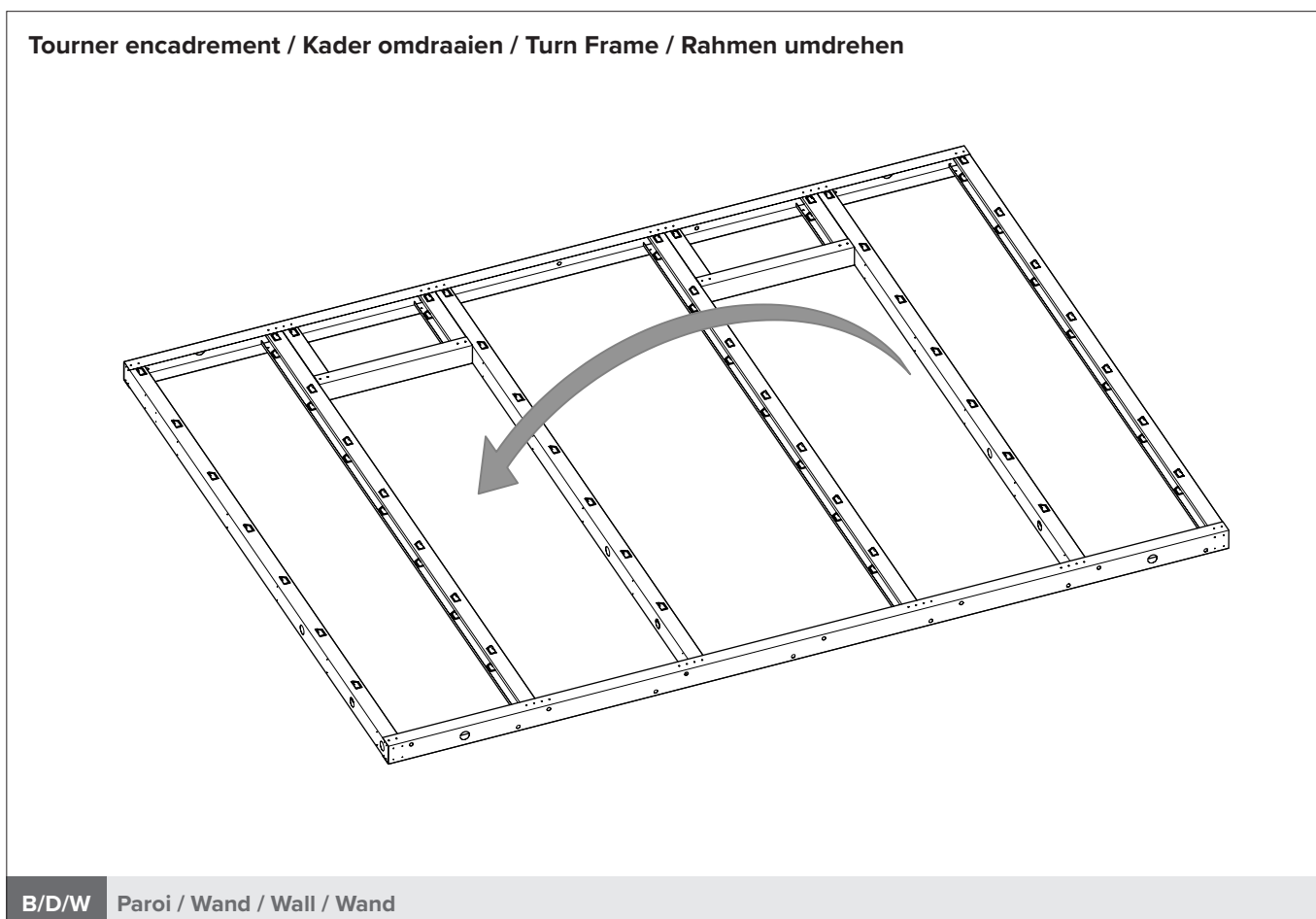
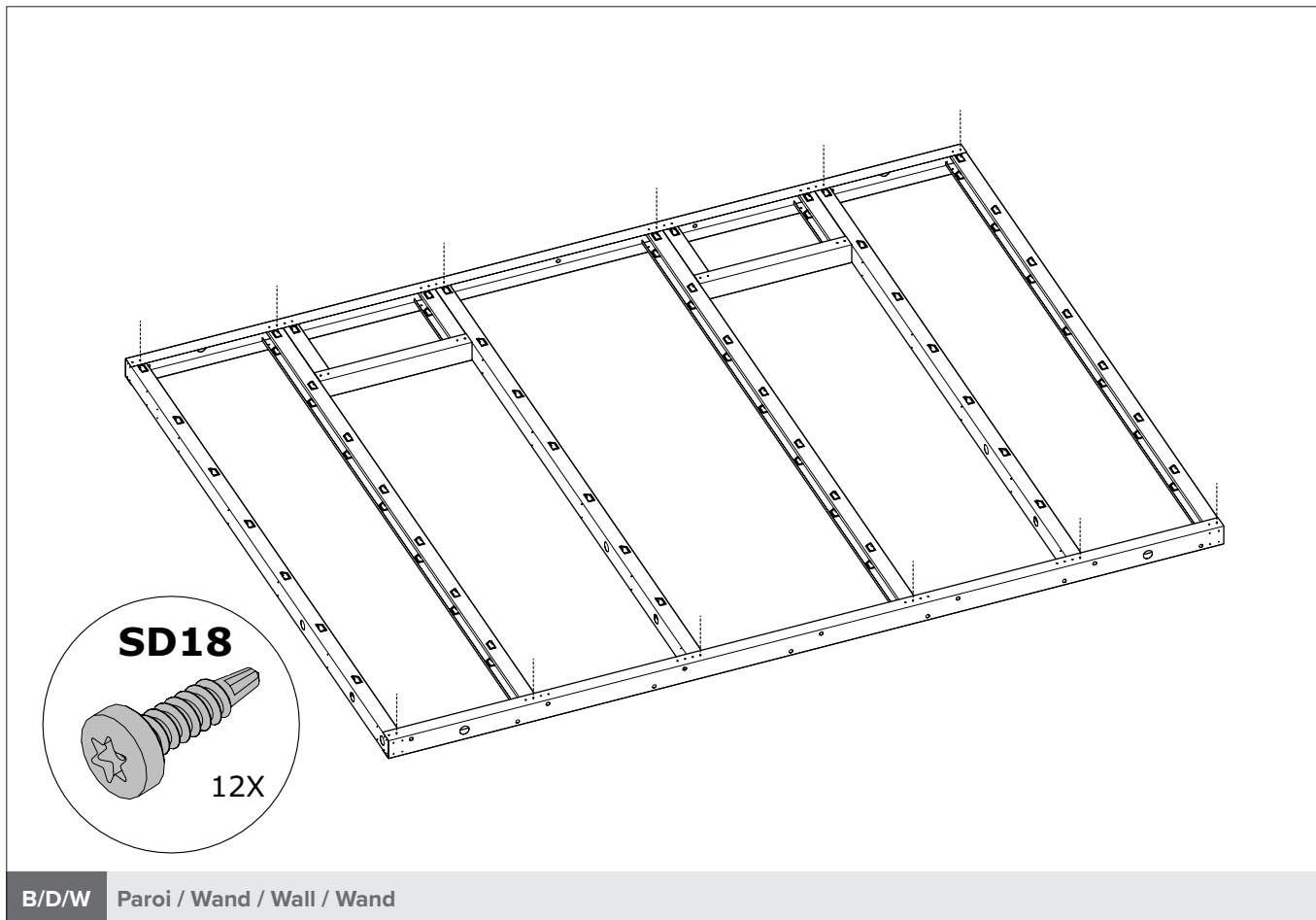

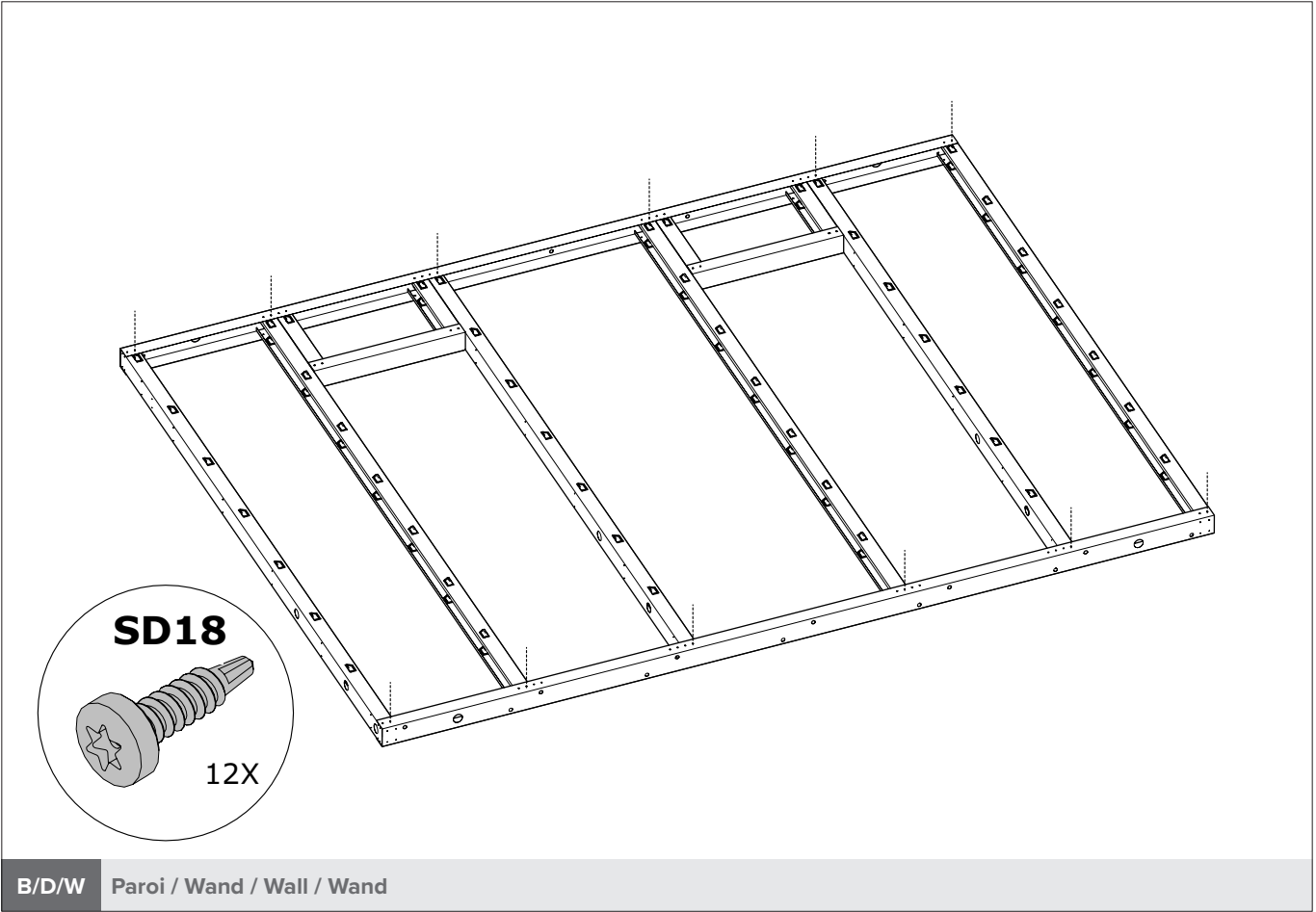

B/D/W Paroi / Wand / Wall / Wand

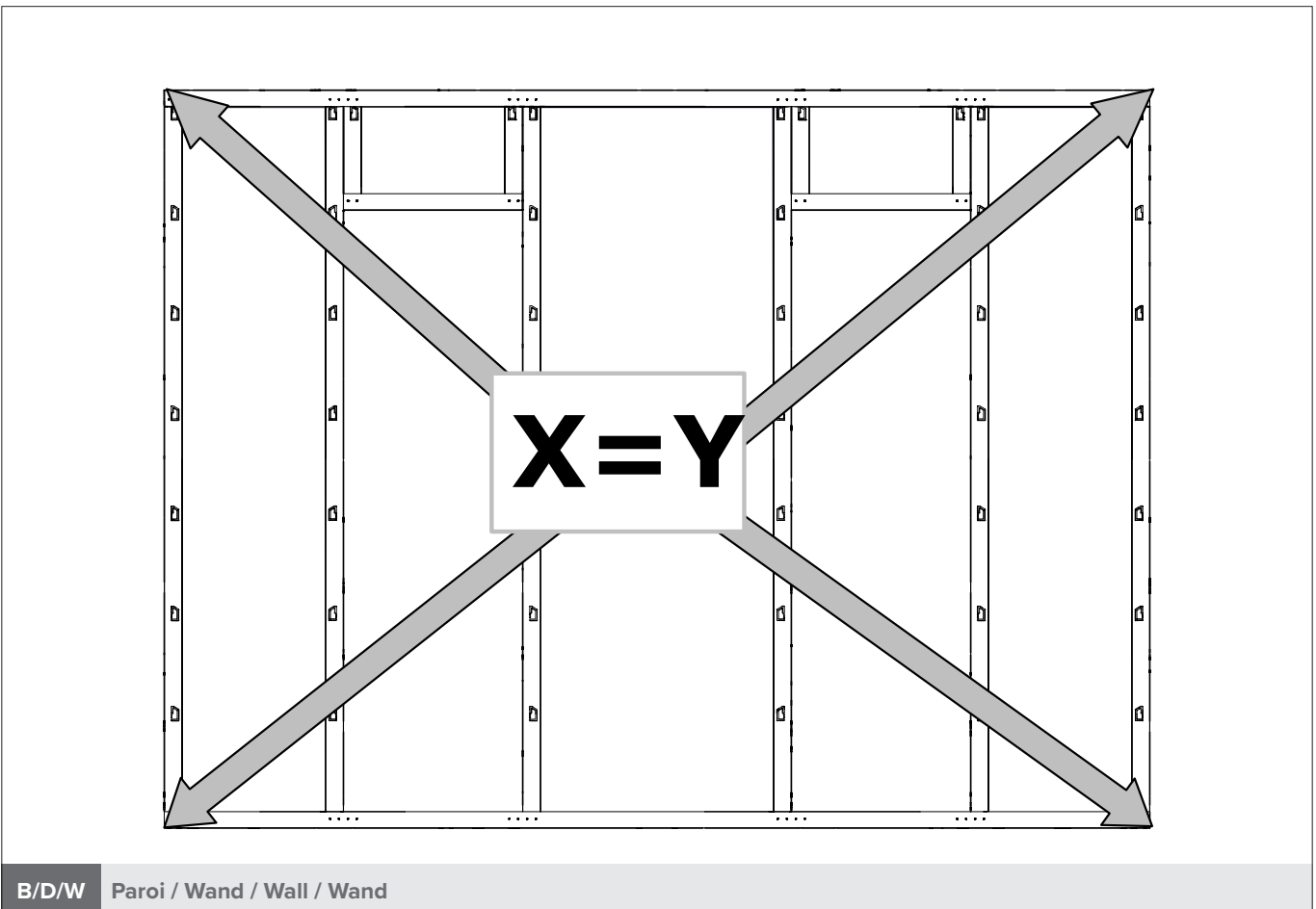

B/D/W Paroi / Wand / Wall / Wand

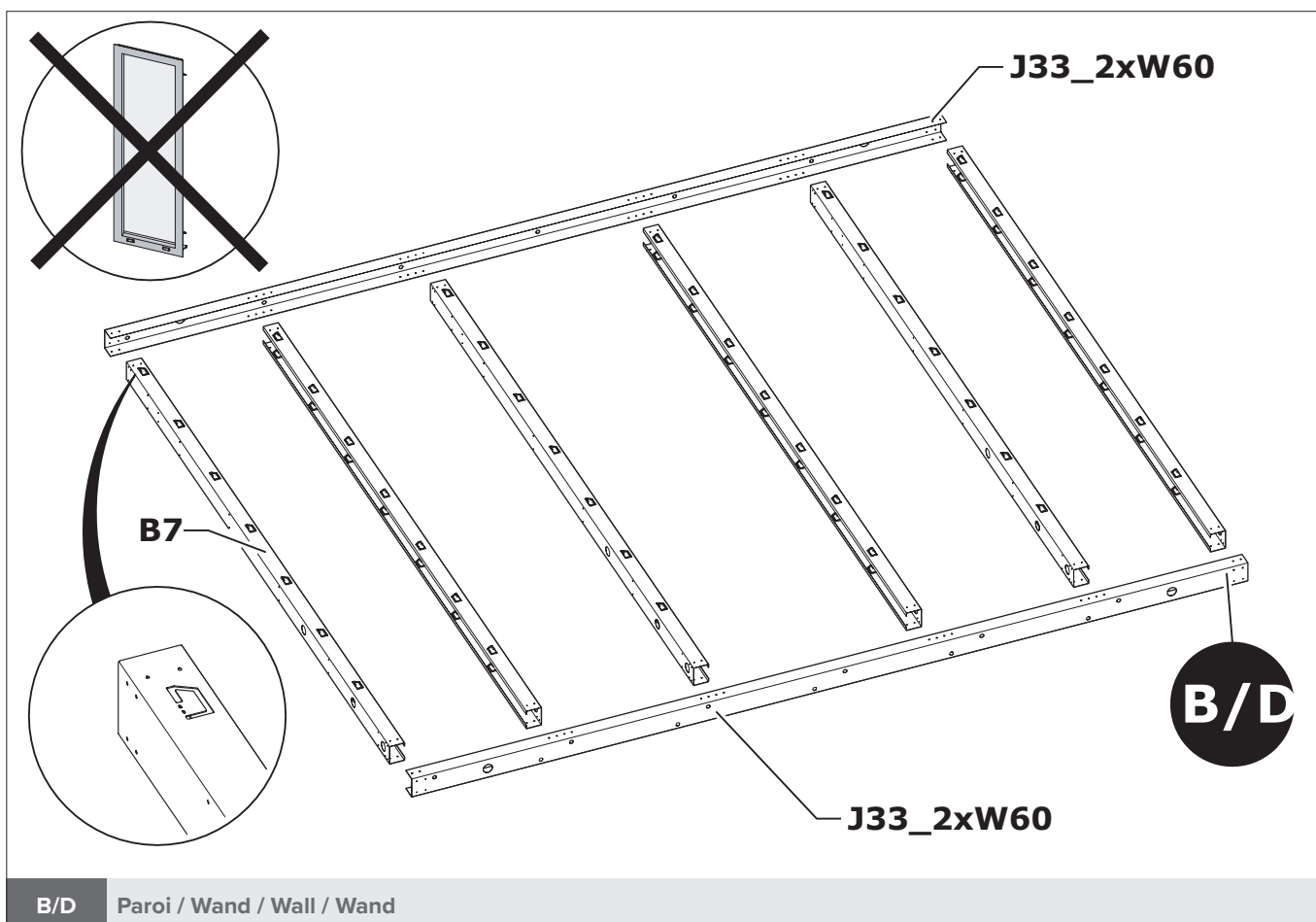
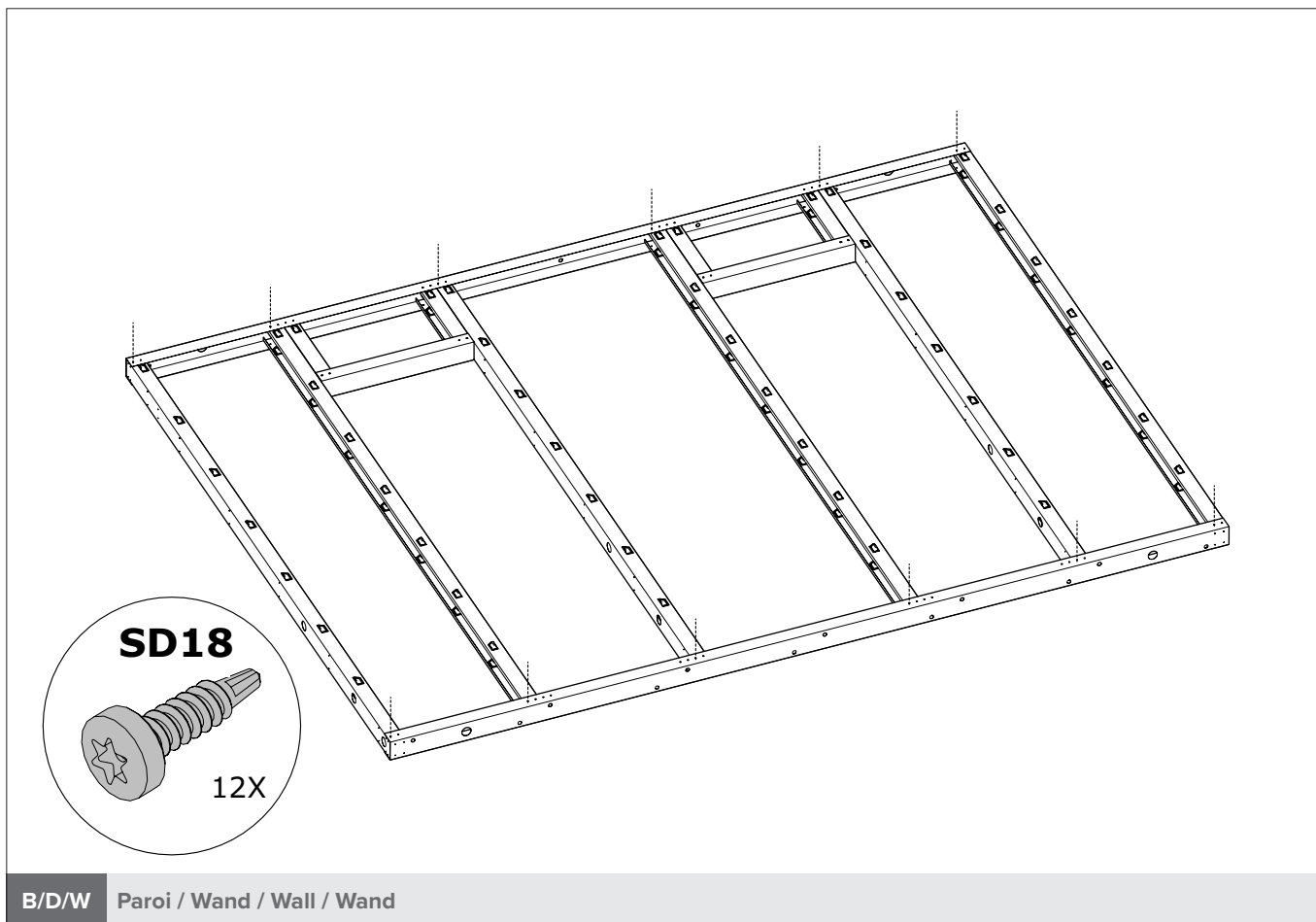

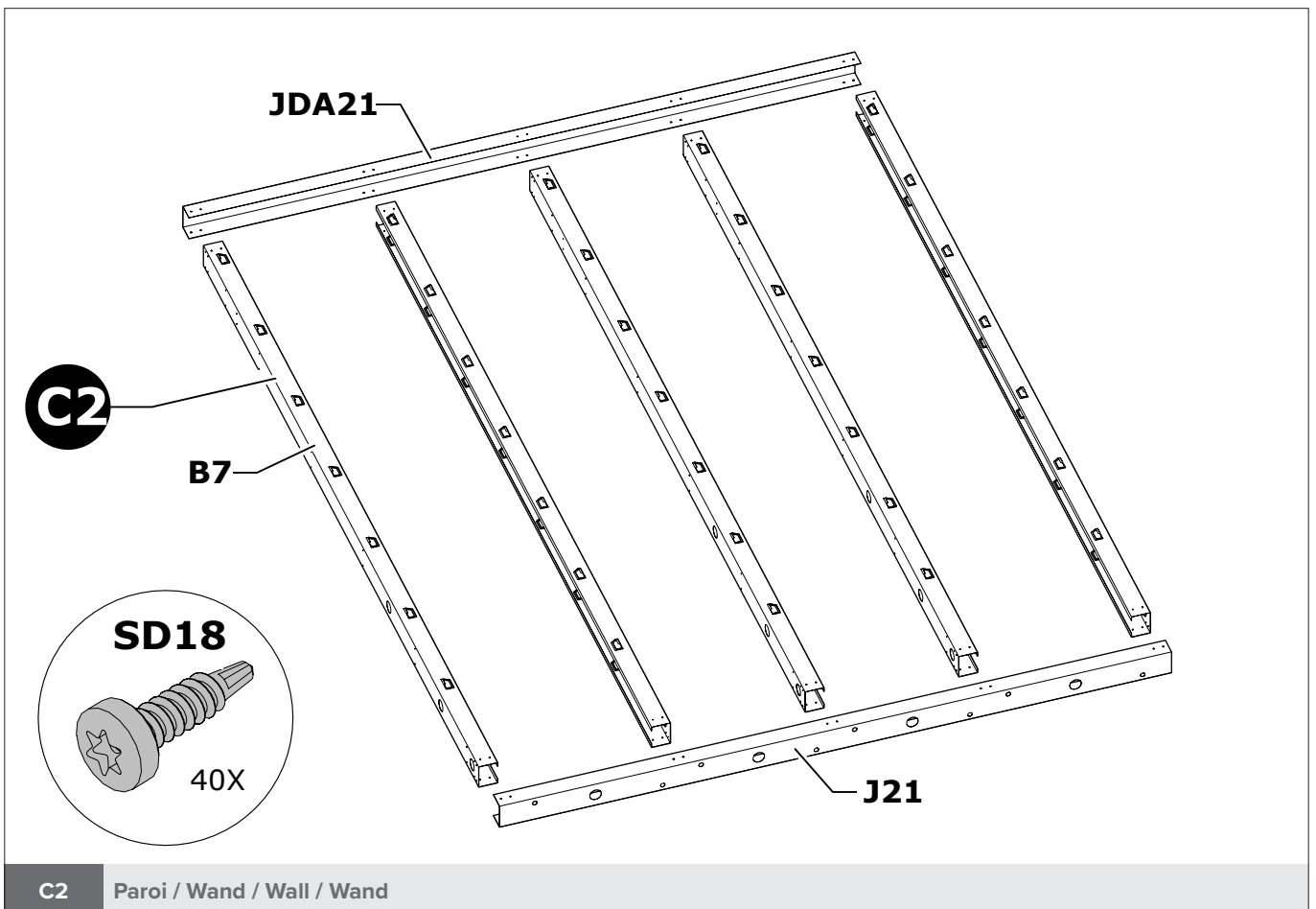
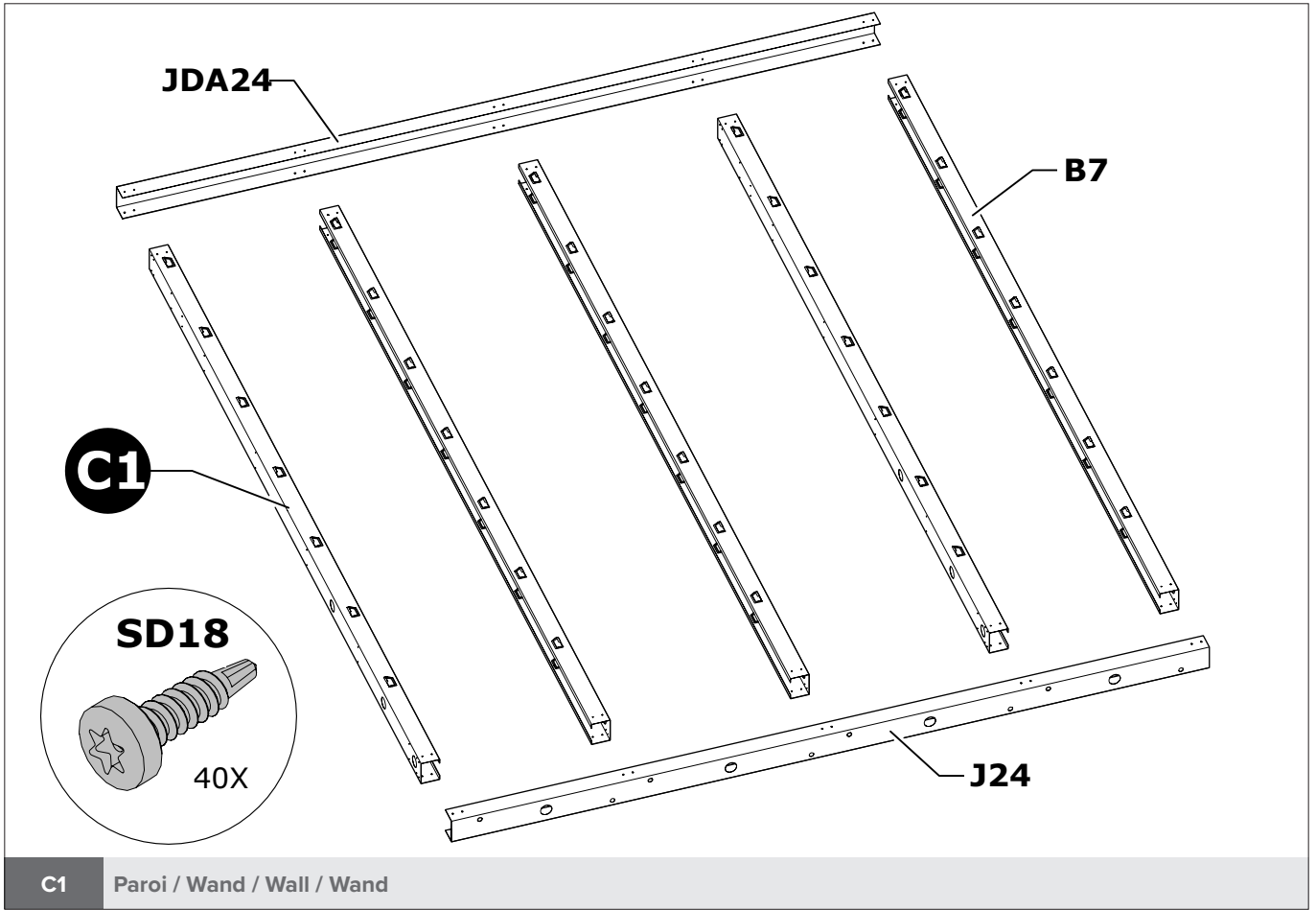

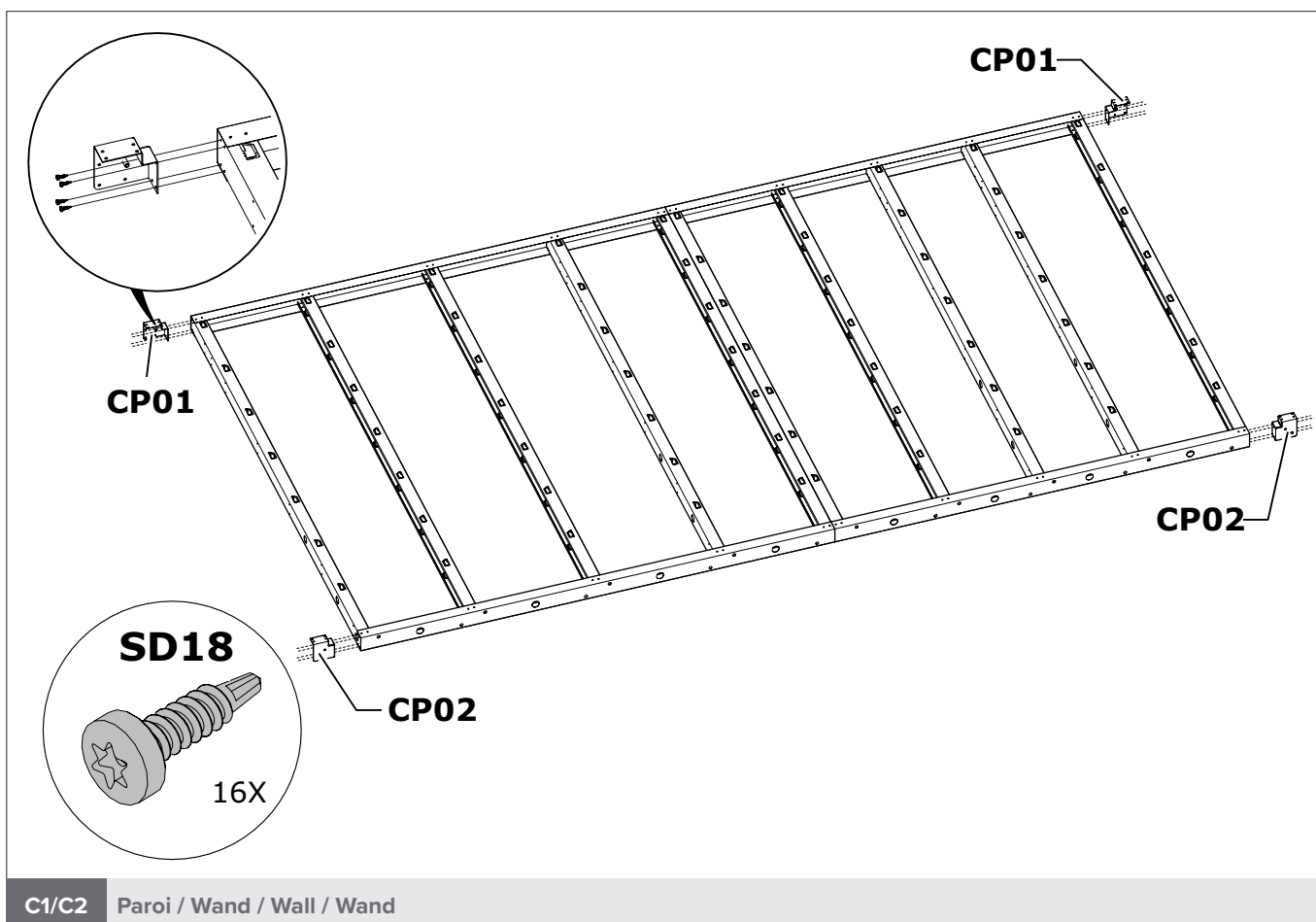
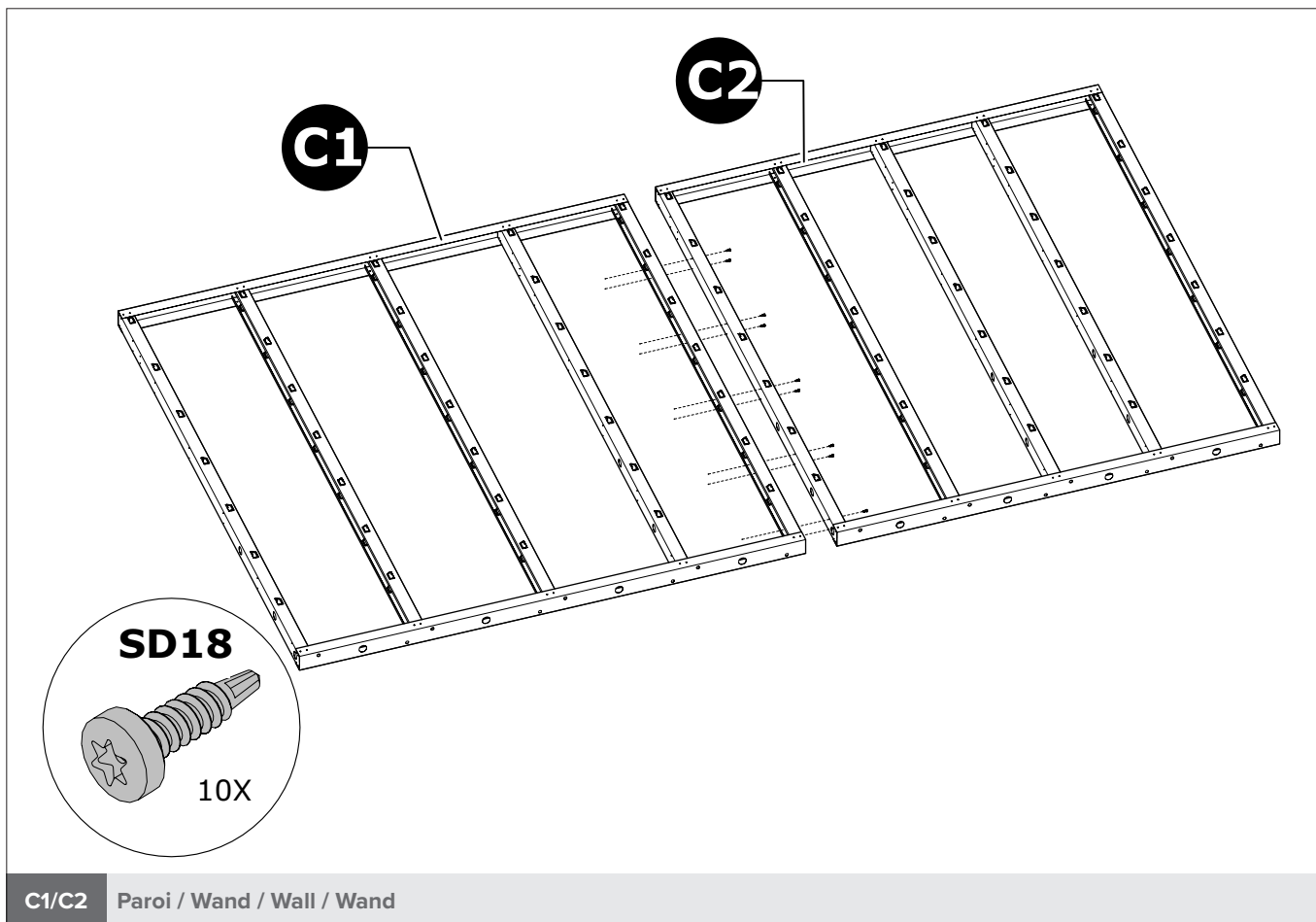

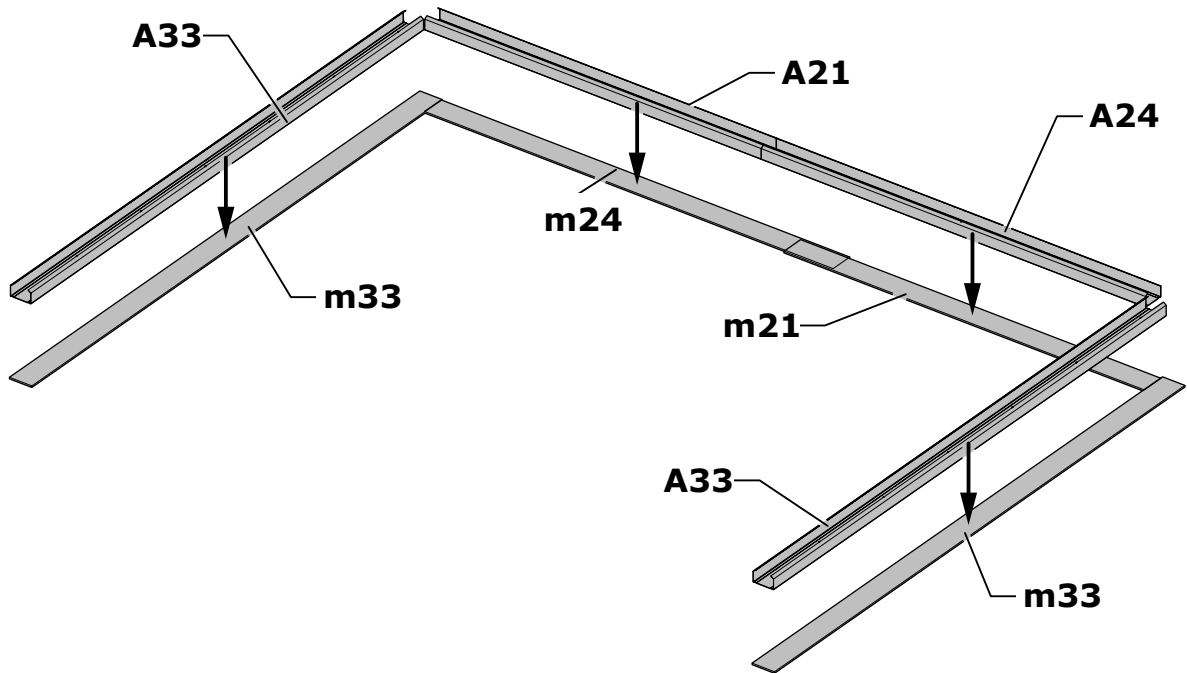

B/C/D Paroi / Wand / Wall / Wand

A24 --> J21

A21 --> J24

C1

C2

D

A24

SD18

8X

A21

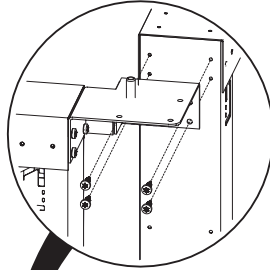

C/D Paroi / Wand / Wall / Wand

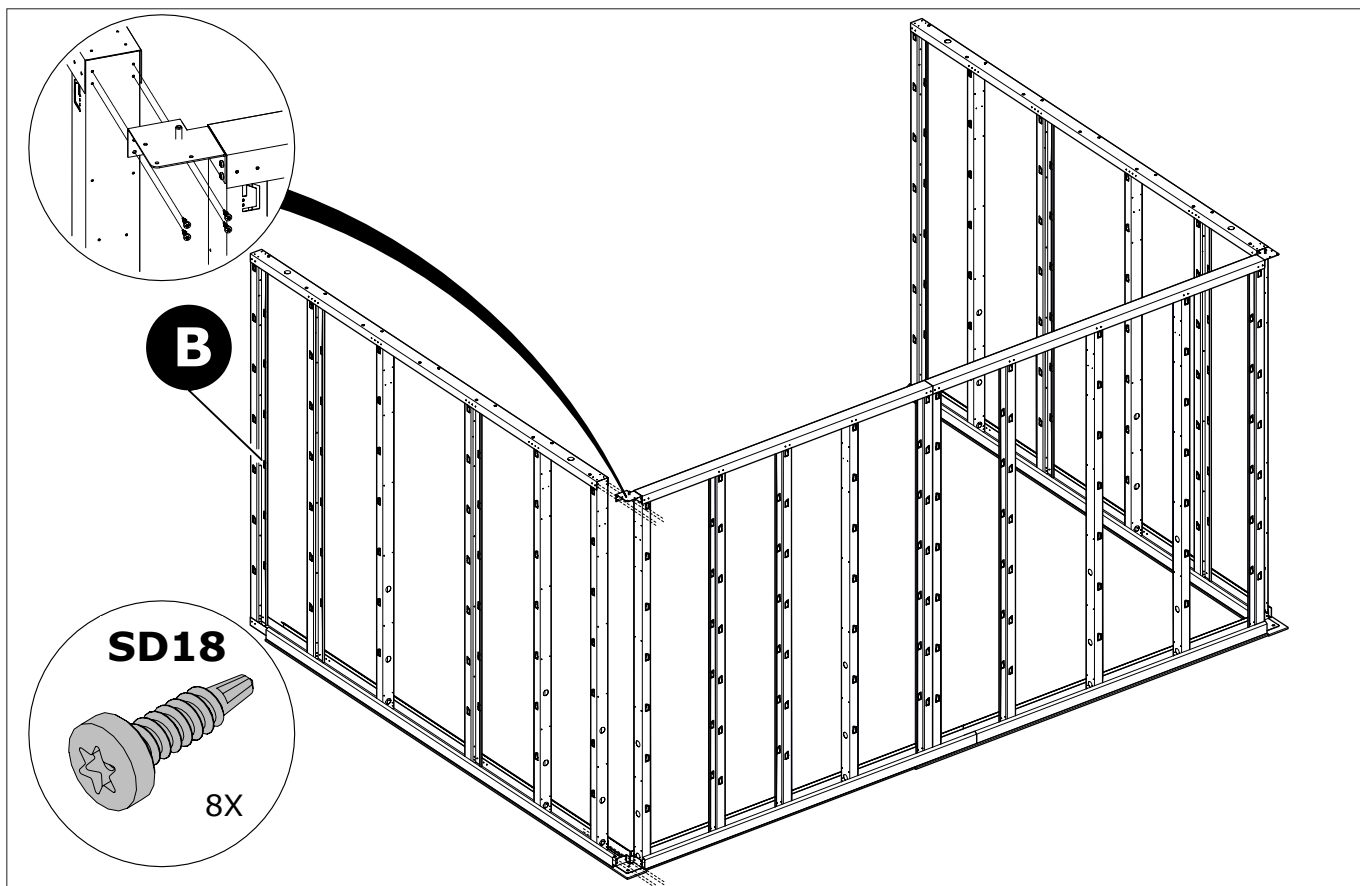

B Paroi / Wand / Wall / Wand

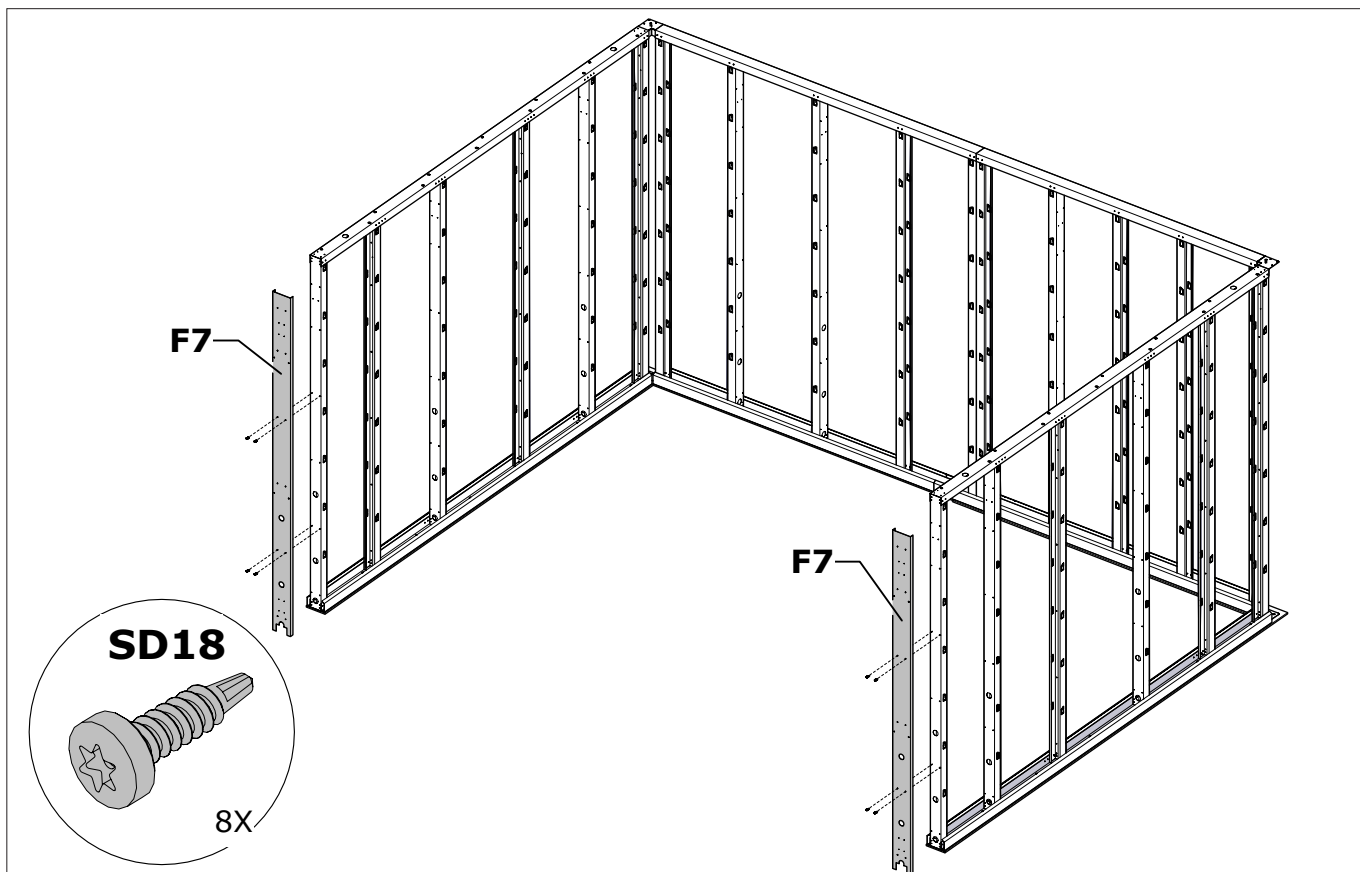

A Paroi / Wand / Wall / Wand

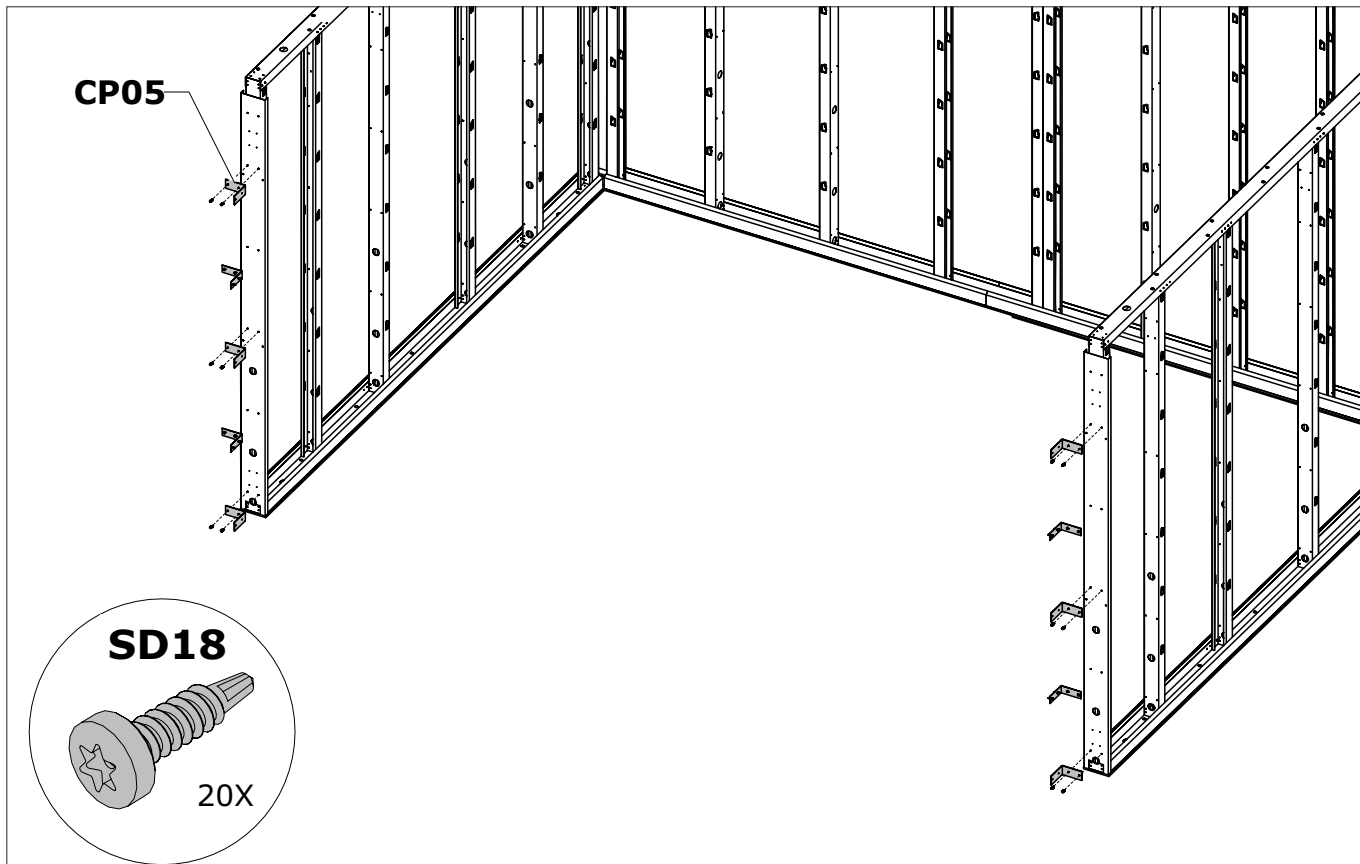

A Paroi / Wand / Wall / Wand

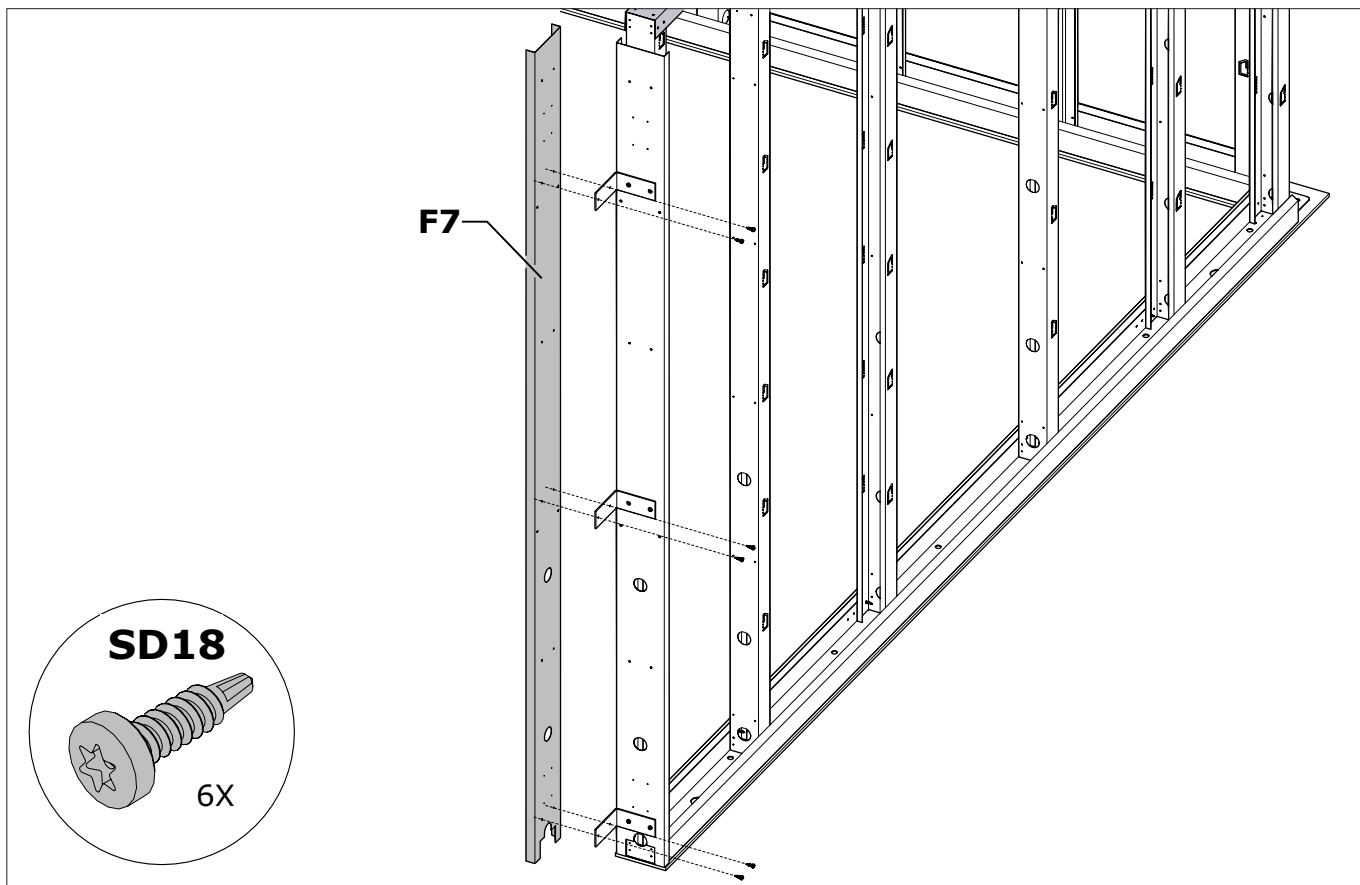

A Paroi / Wand / Wall / Wand

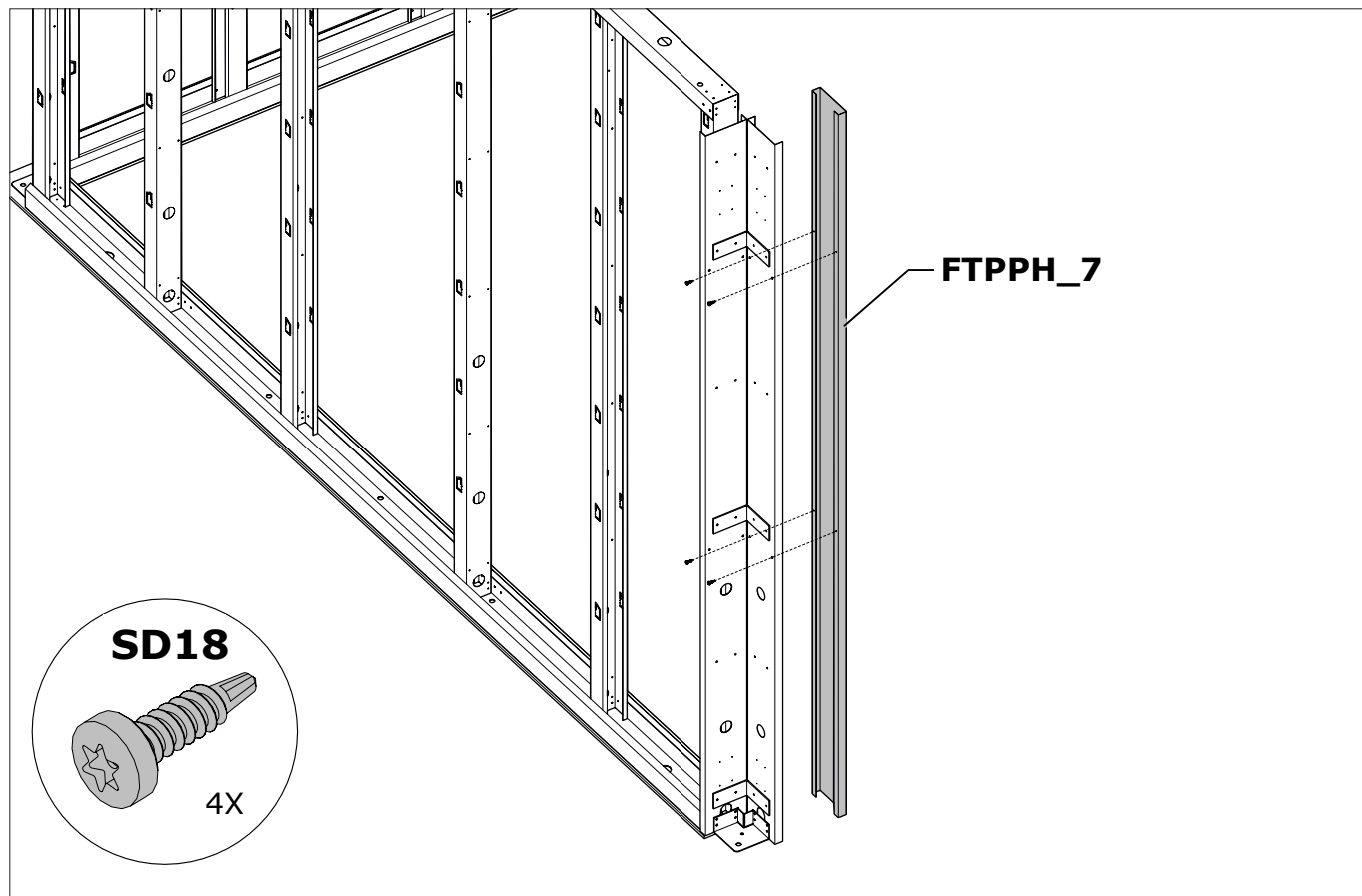

A Paroi / Wand / Wall / Wand

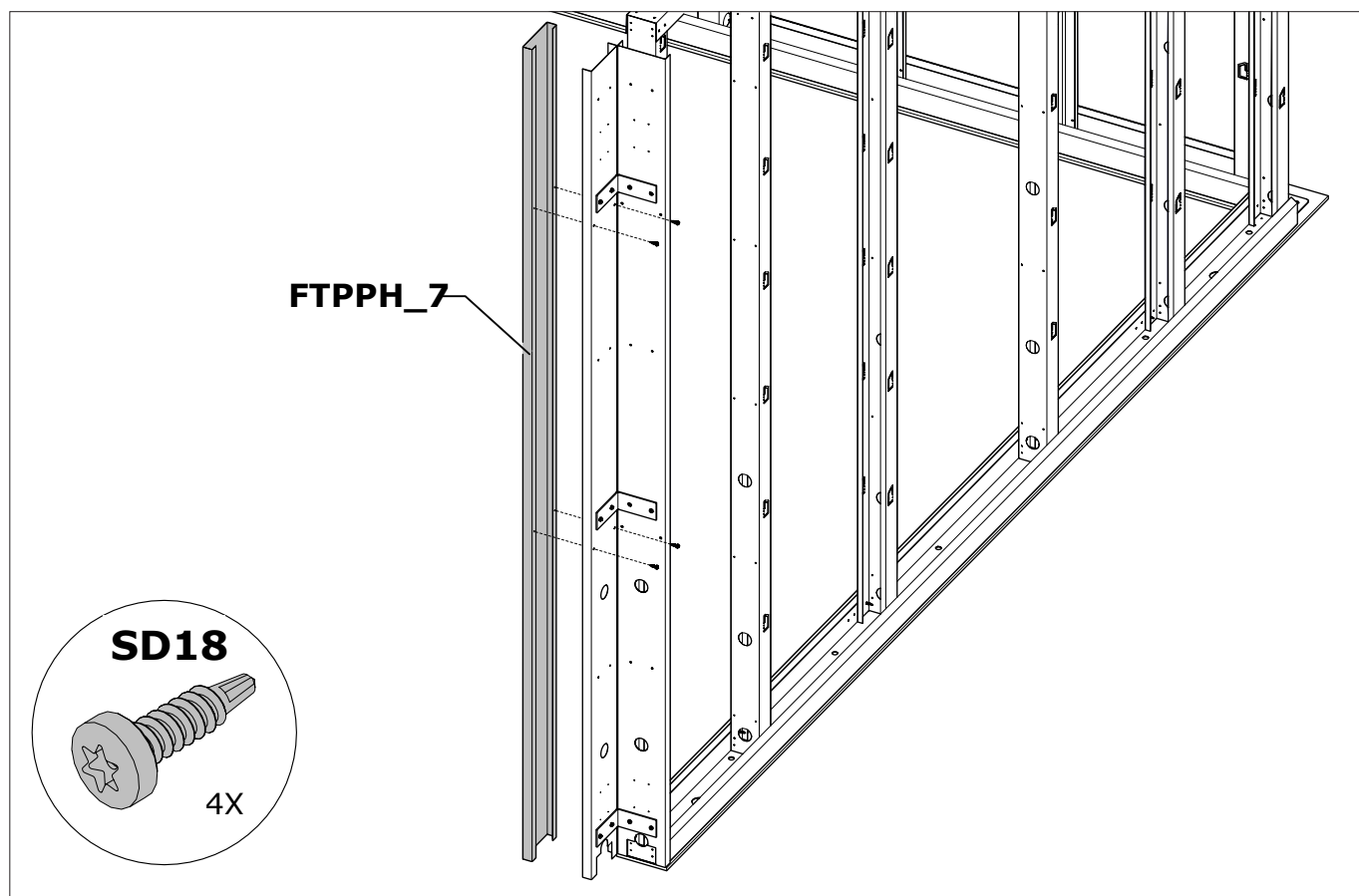

A Paroi / Wand / Wall / Wand

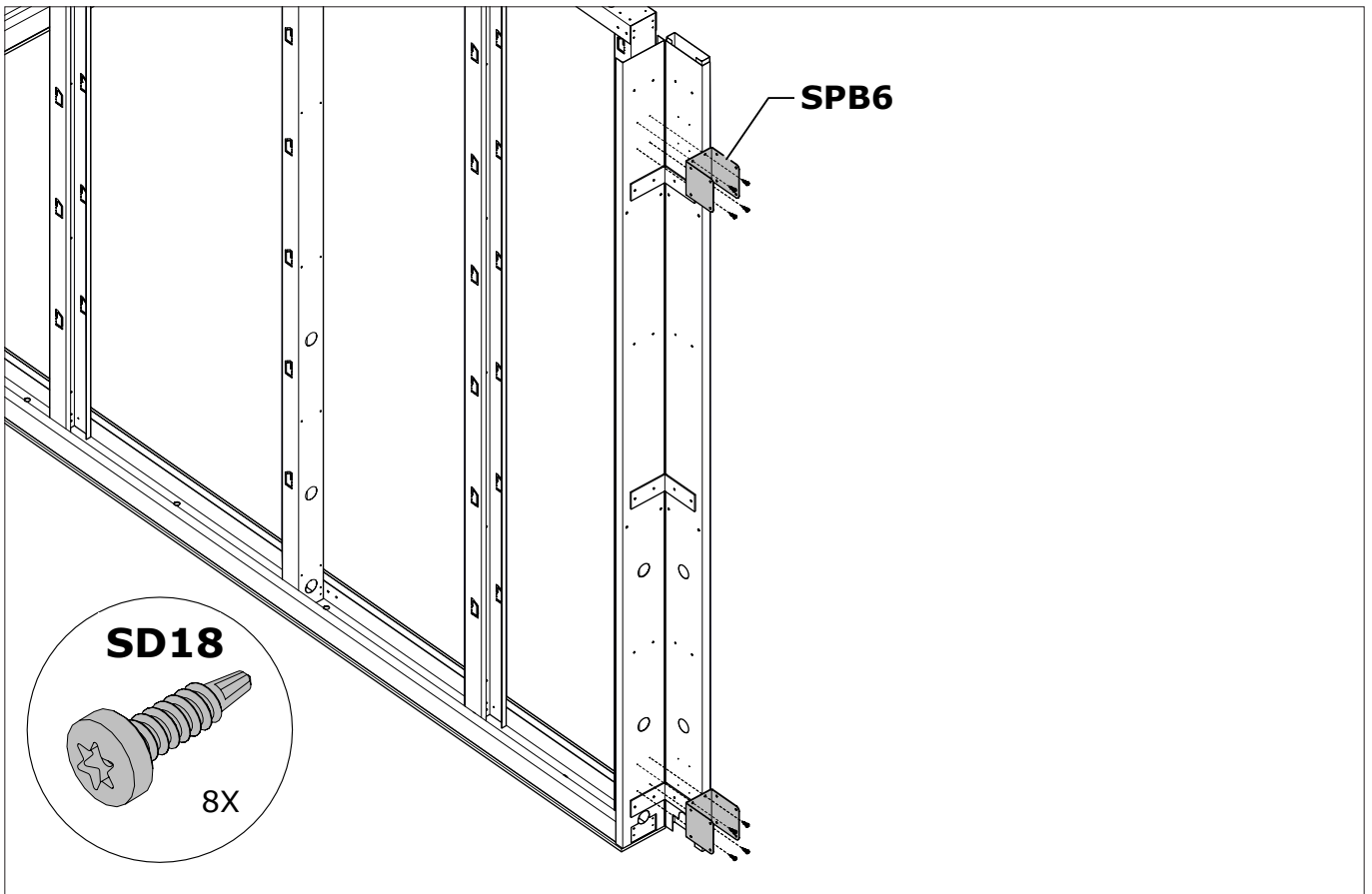

A Paroi / Wand / Wall / Wand

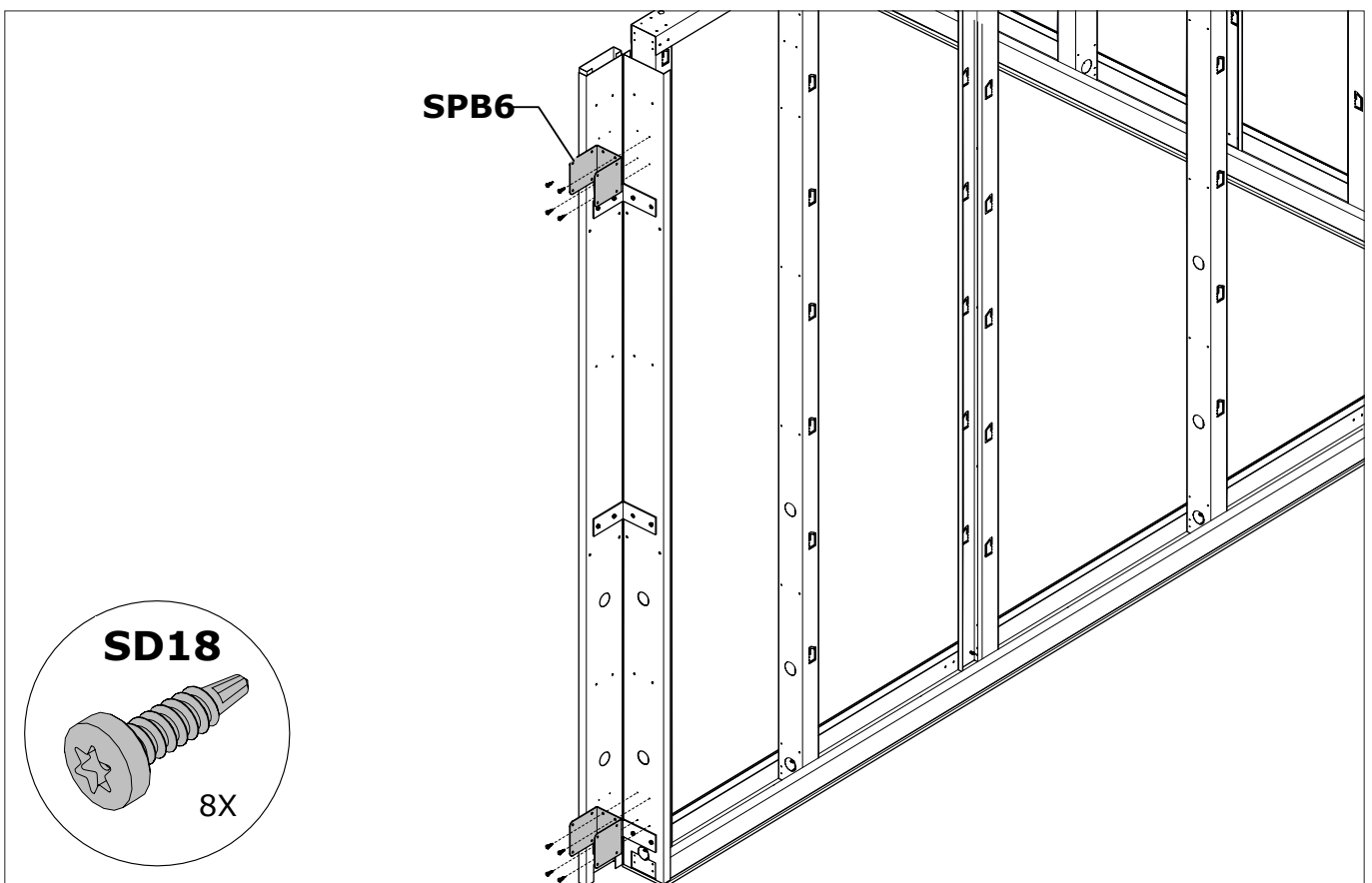

A Paroi / Wand / Wall / Wand

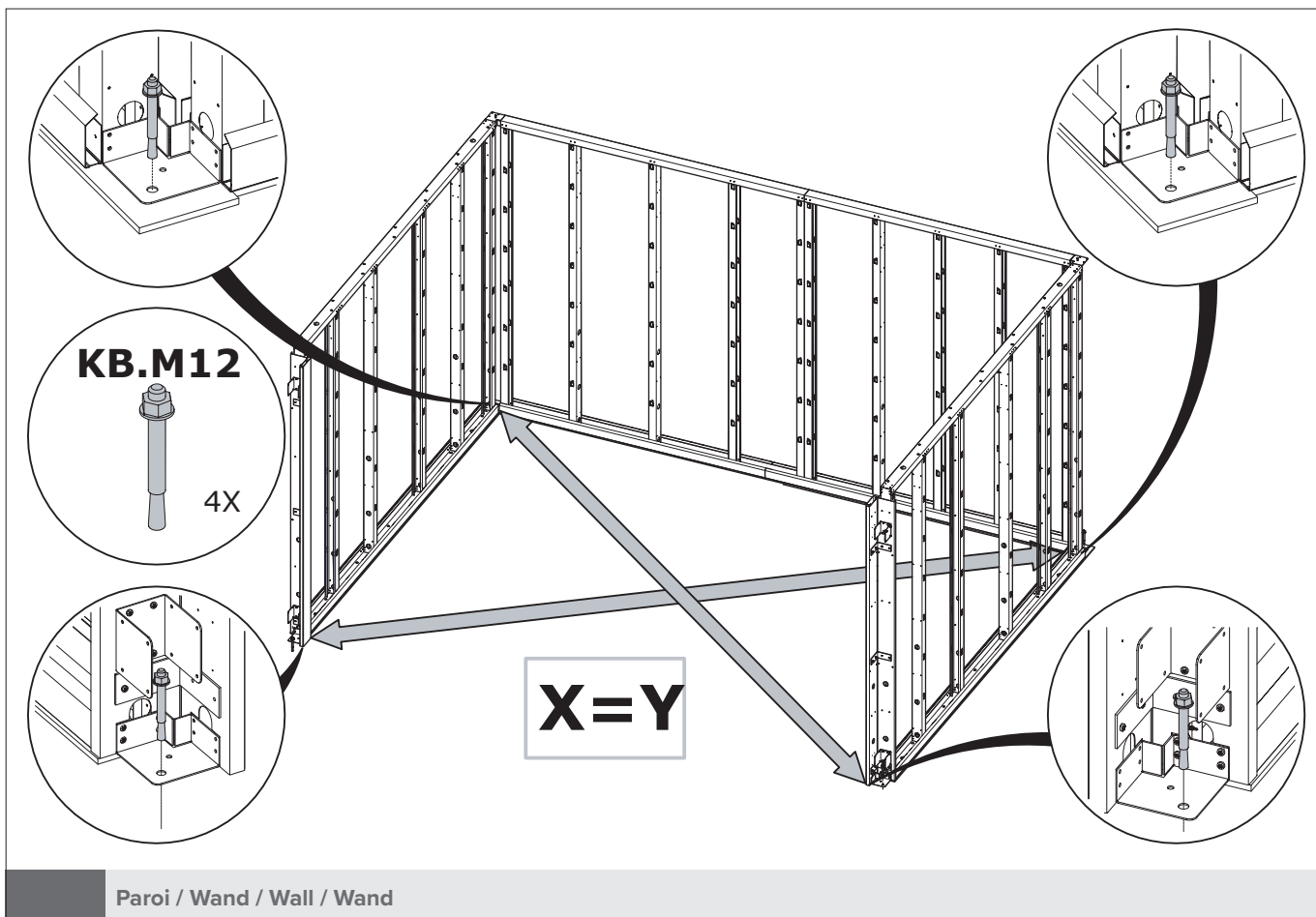
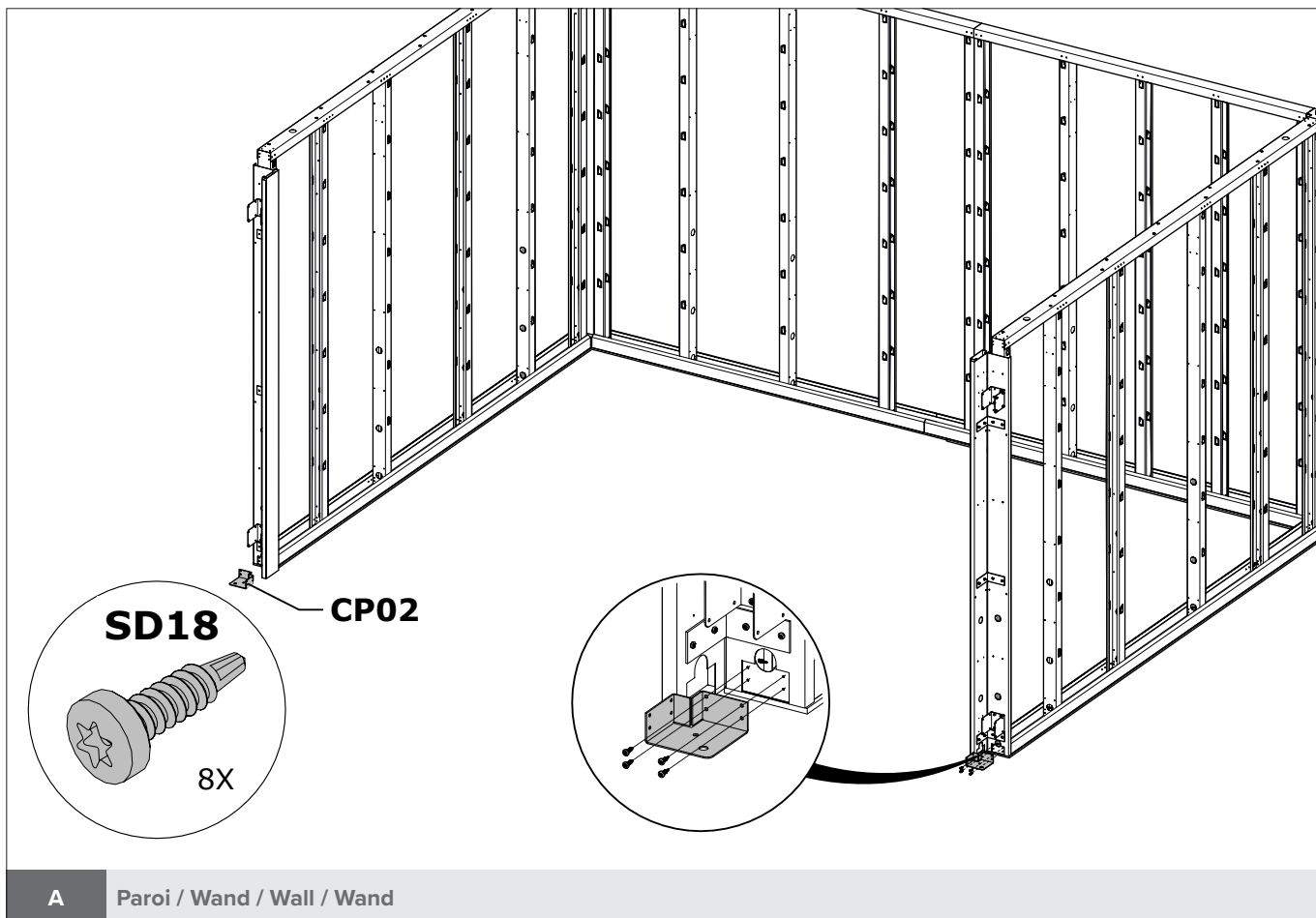

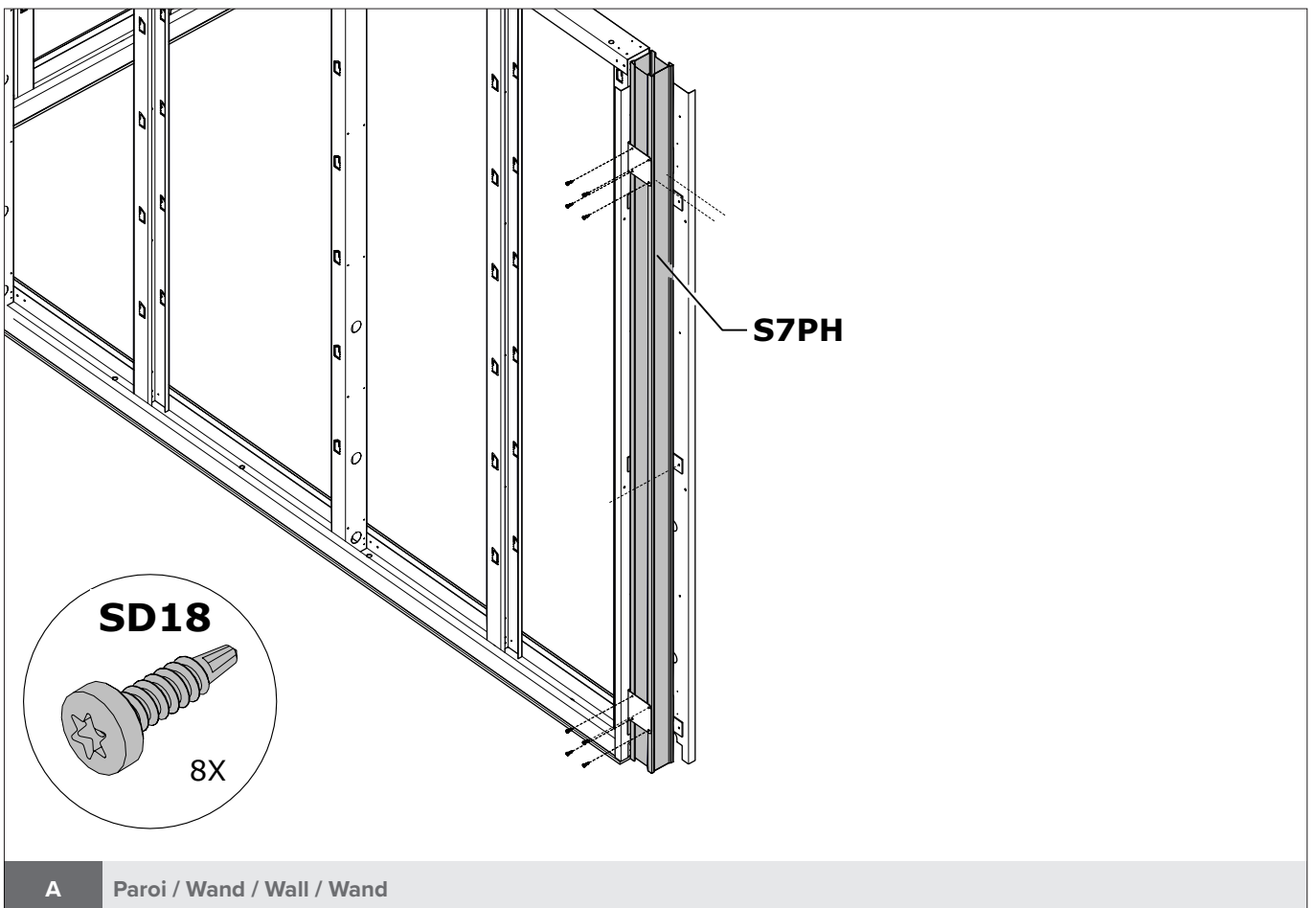
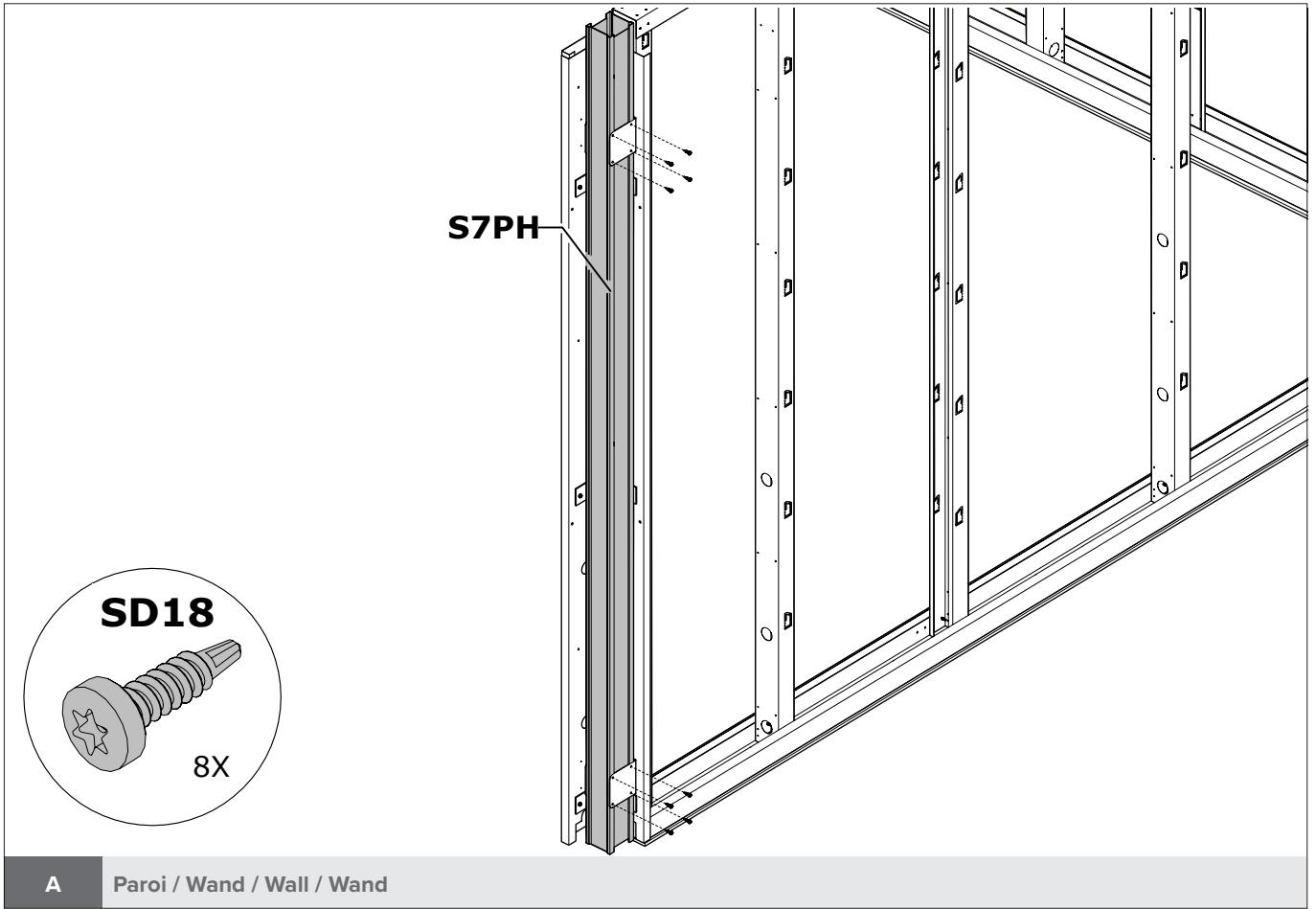

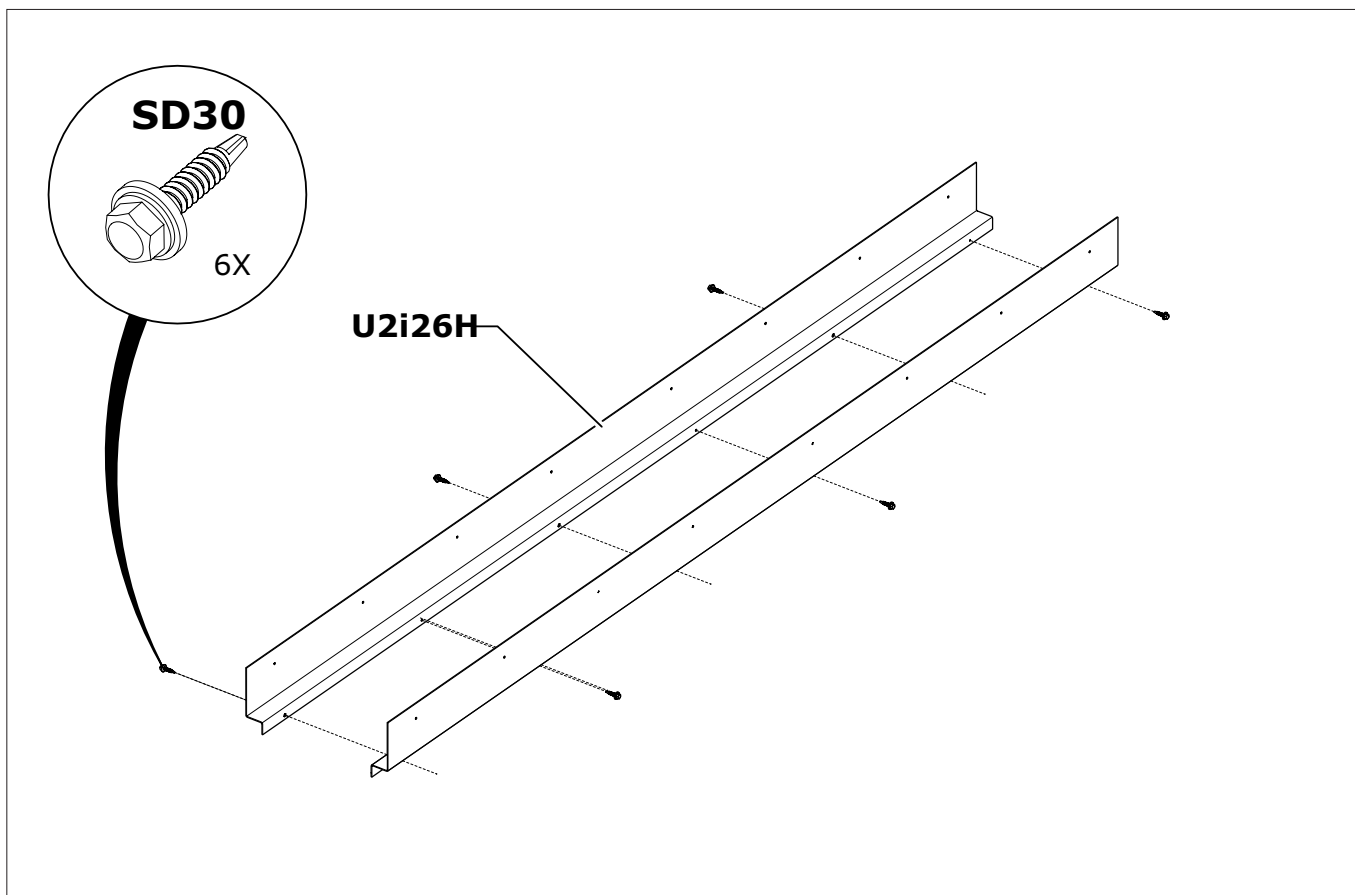

A Paroi / Wand / Wall / Wand

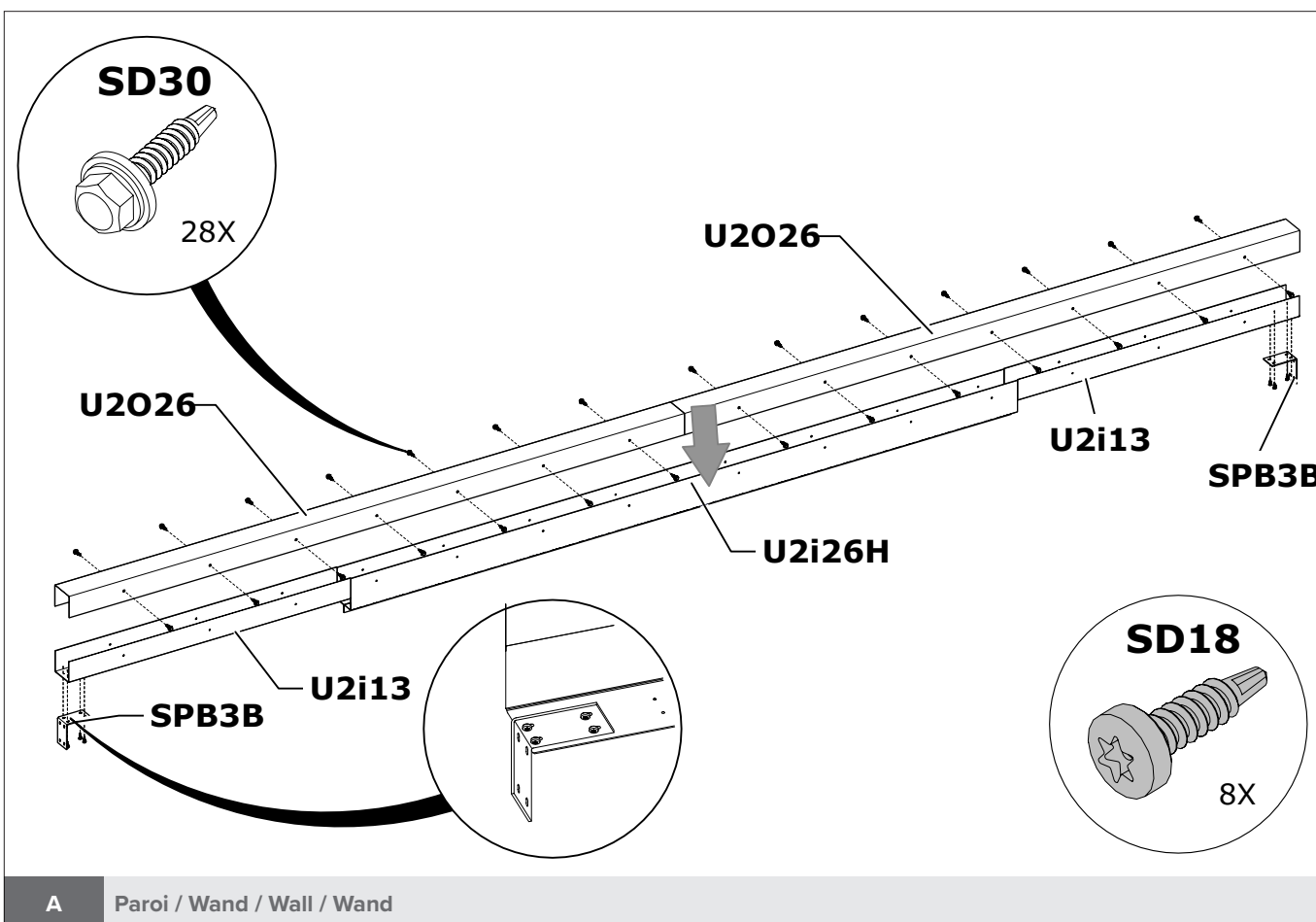

A Paroi / Wand / Wall / Wand

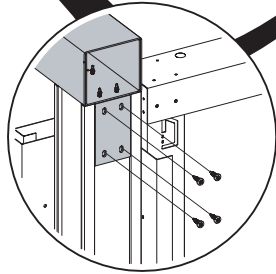
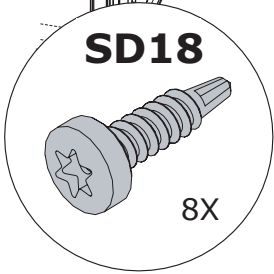
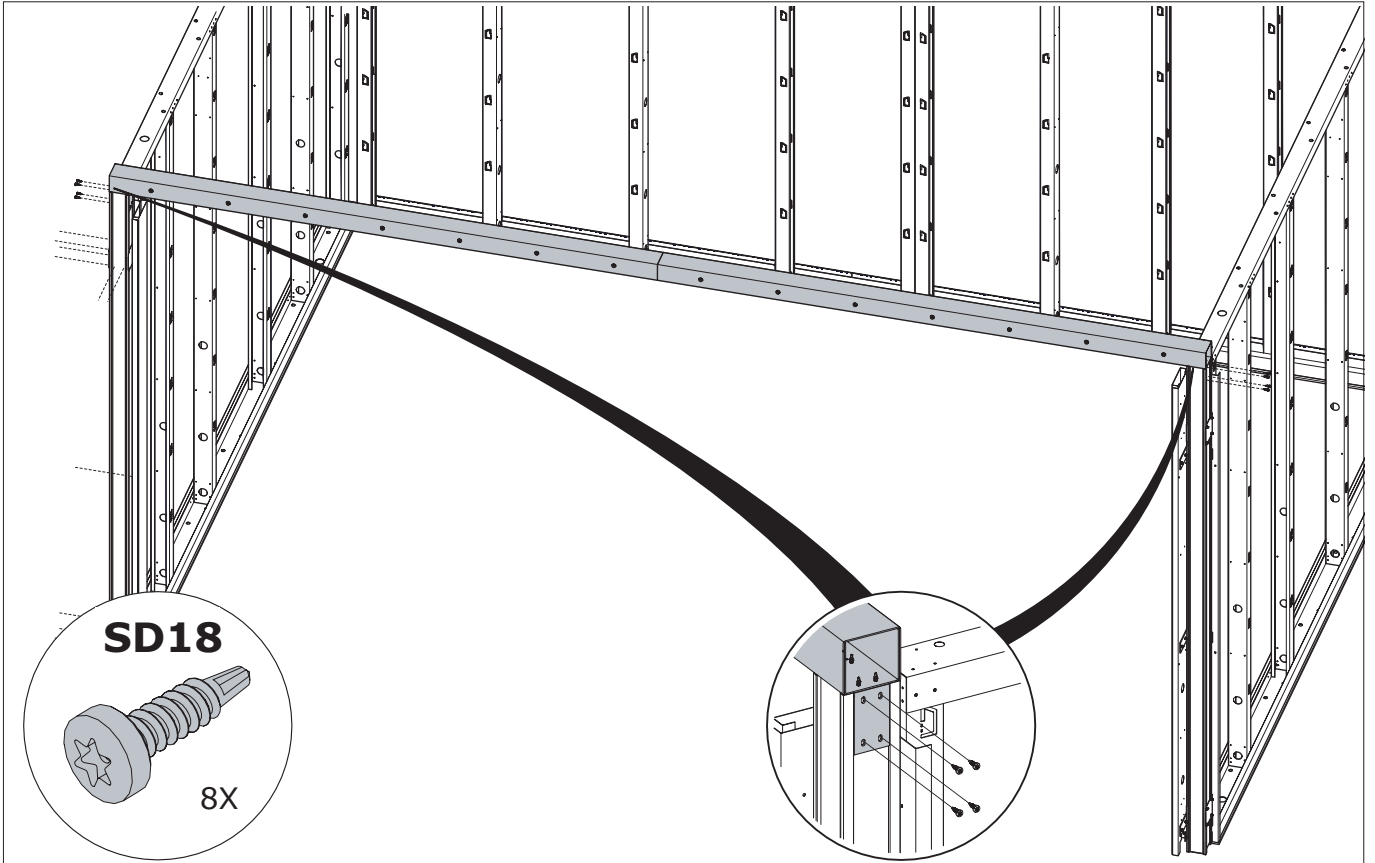

A Paroi / Wand / Wall / Wand

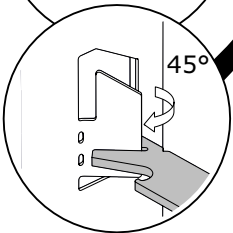
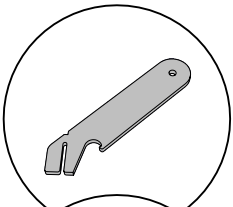
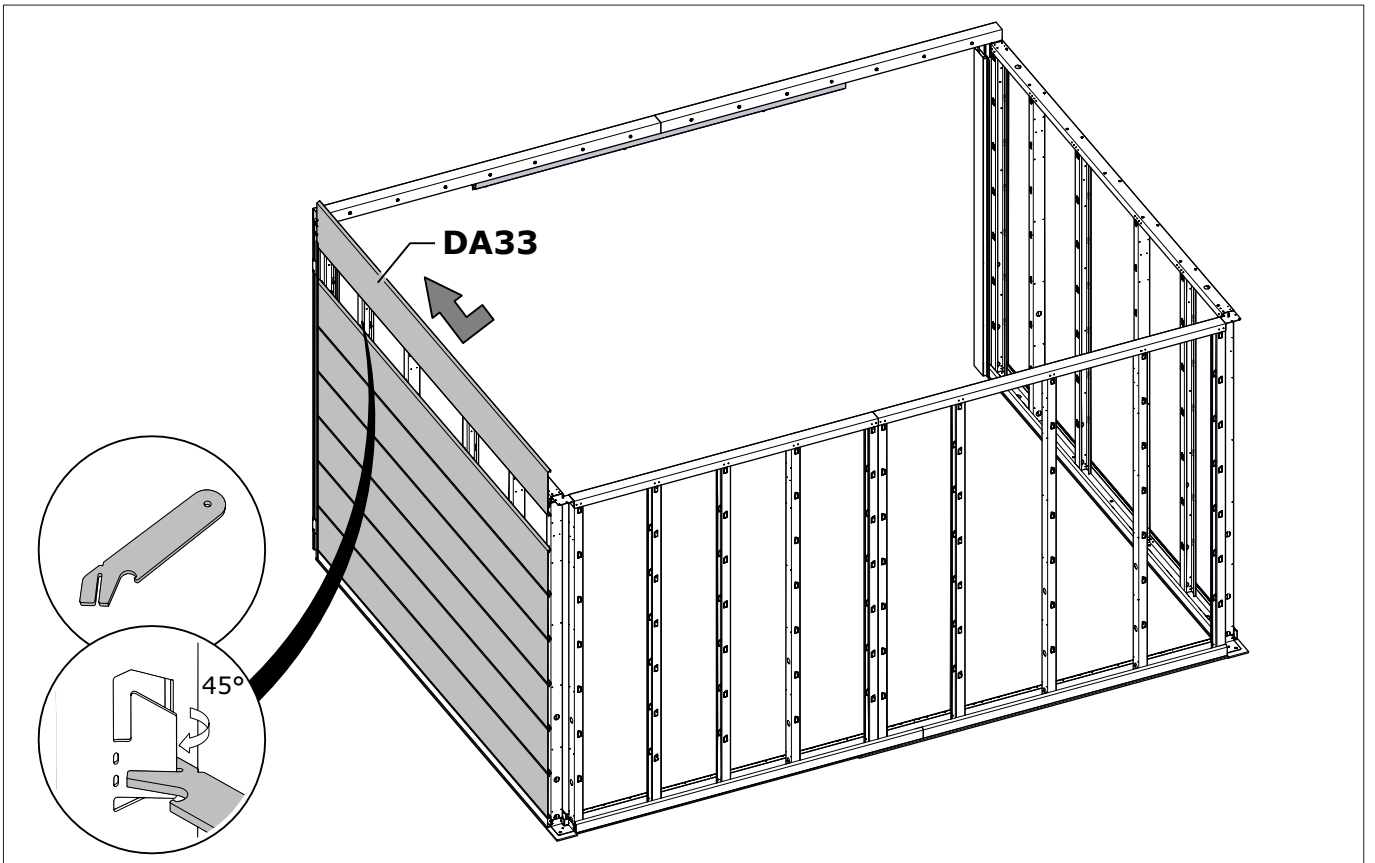

B Paroi / Wand / Wall / Wand

Optie electriciteit, installeer de kabels nu. LET OP! verleng de kabel van de spot nu al.

Option électricité, installez les câbles maintenant. Attention, il vous faut positionner le câble des spots maintenant.

Electricity option, install the cables now. WARNING! extend the spotlight's cable now.

Stromoption, installieren Sie nun die Kabel. ACHTUNG! Verlängern Sie jetzt das Kabel des Spots.



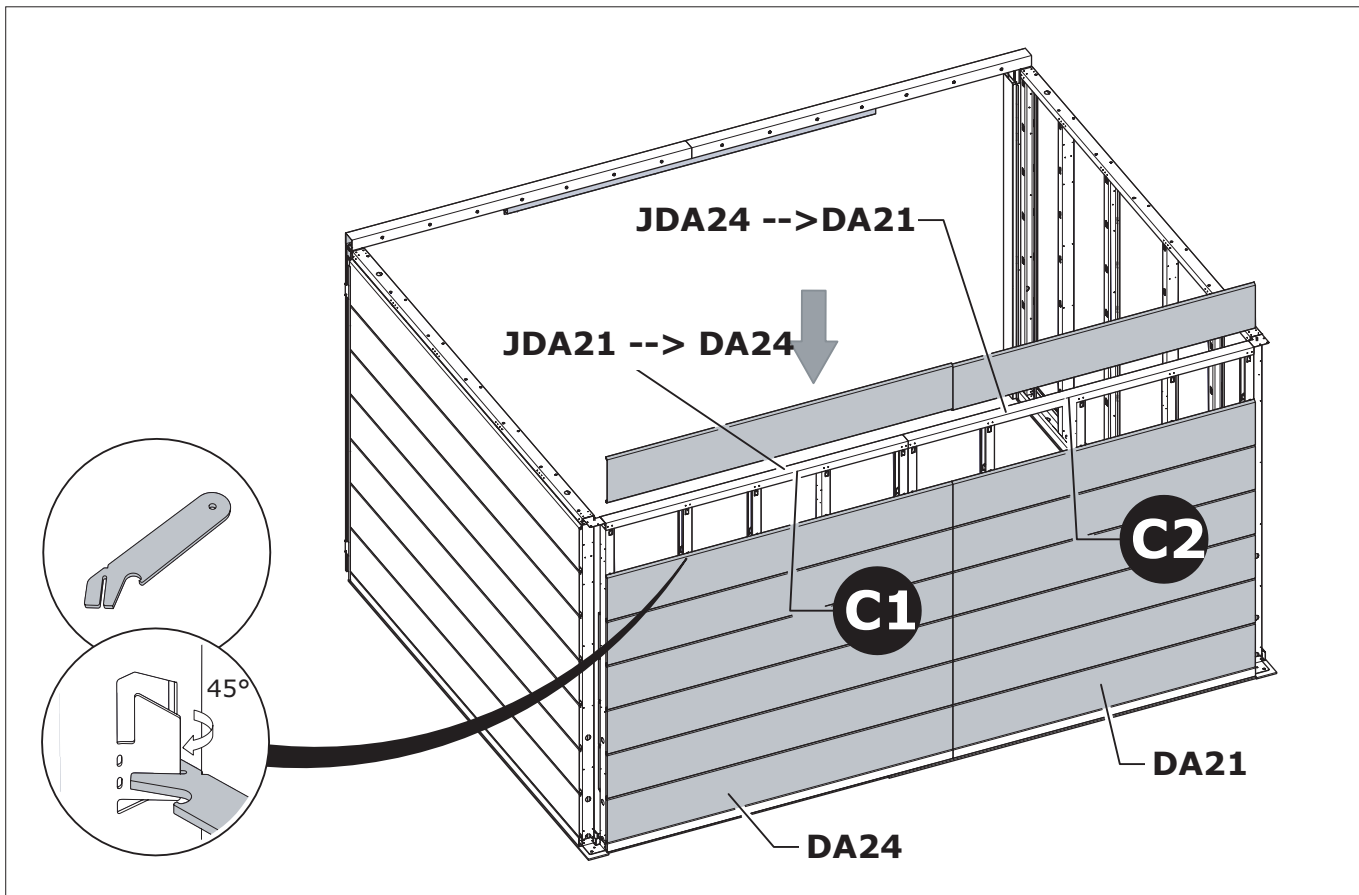

C Paroi / Wand / Wall / Wand

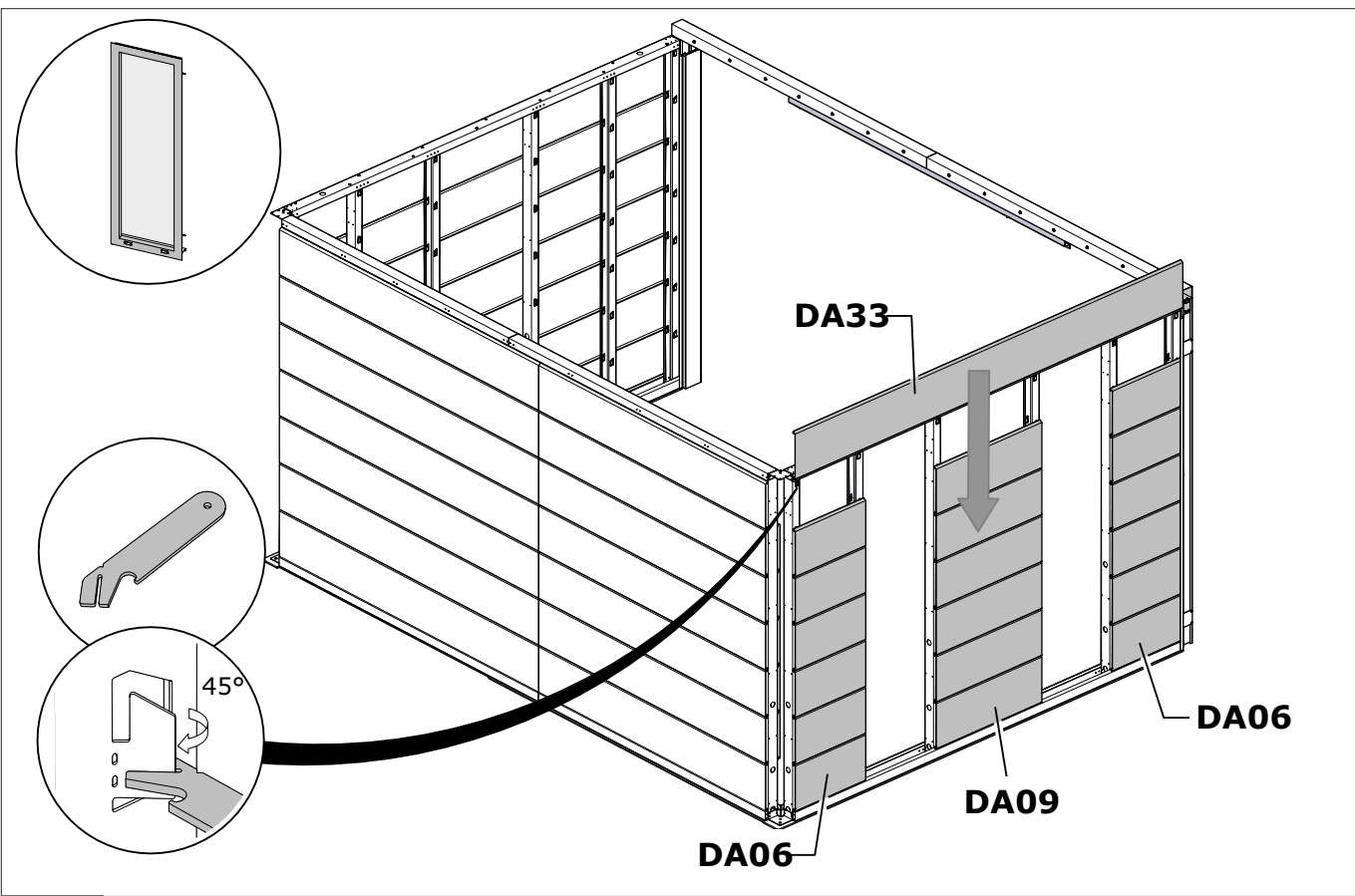

W Paroi / Wand / Wall / Wand

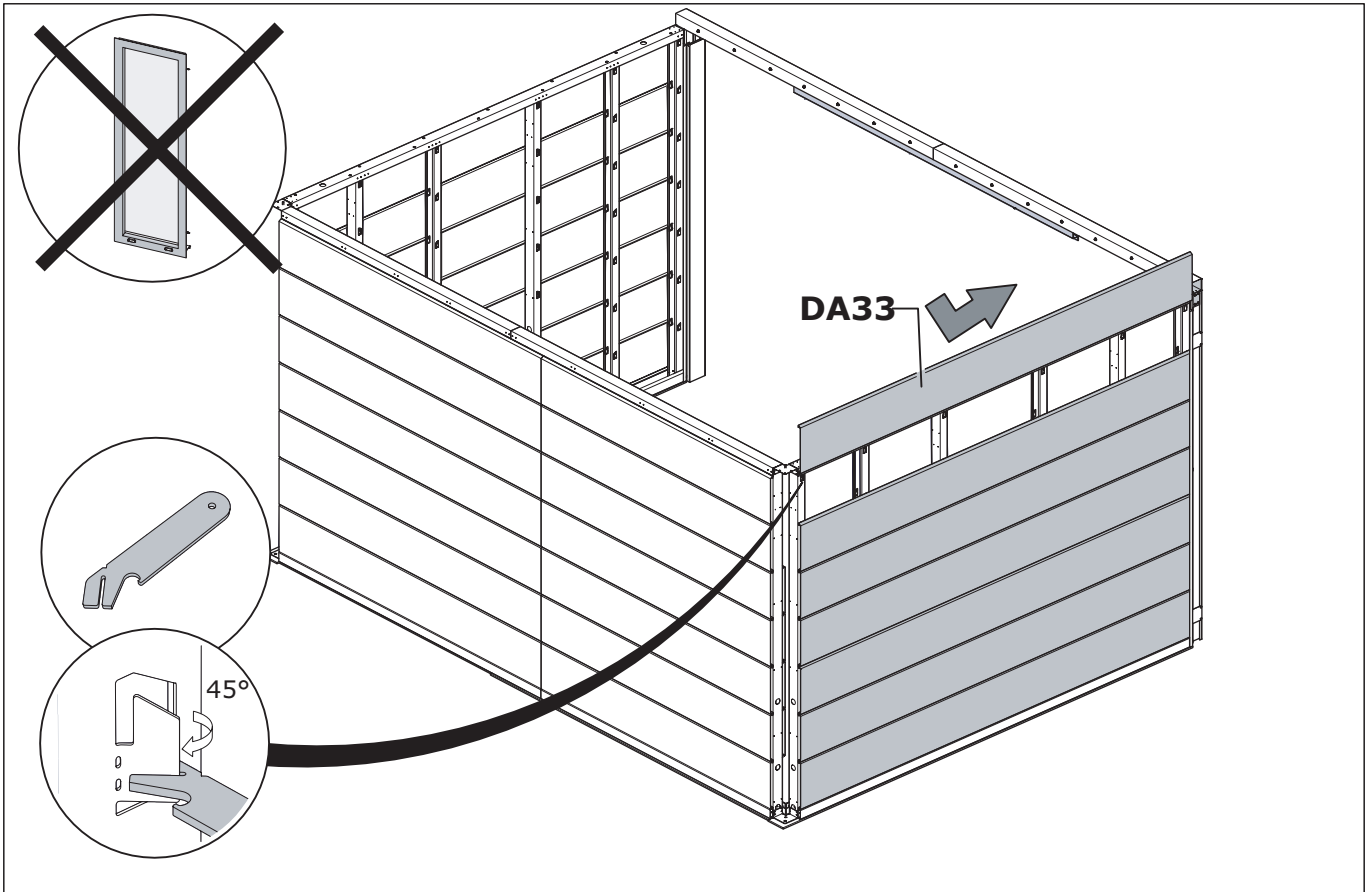

D Paroi / Wand / Wall / Wand

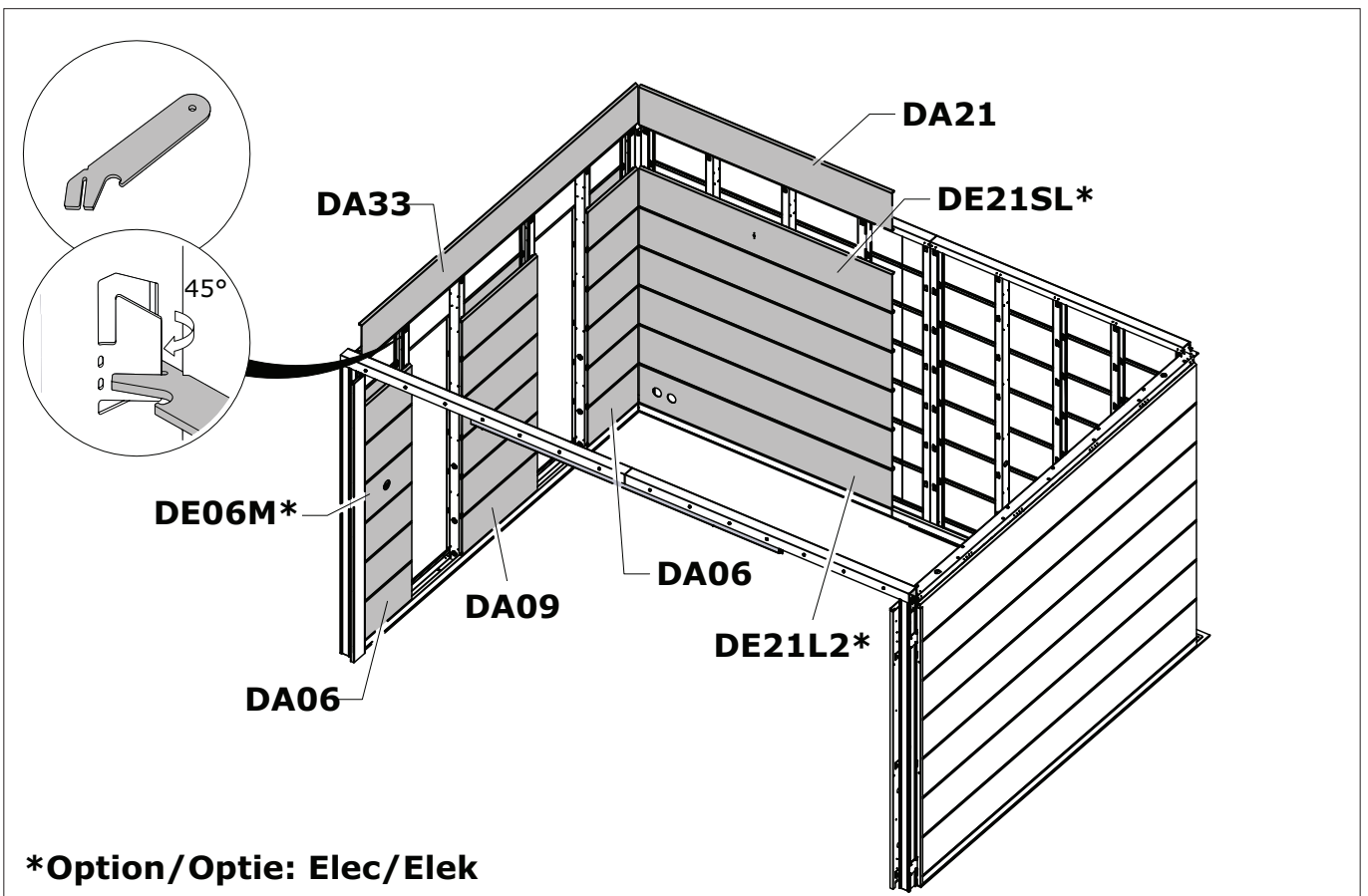

***Option/Optie: Elec/Elek**

C/D Paroi / Wand / Wall / Wand

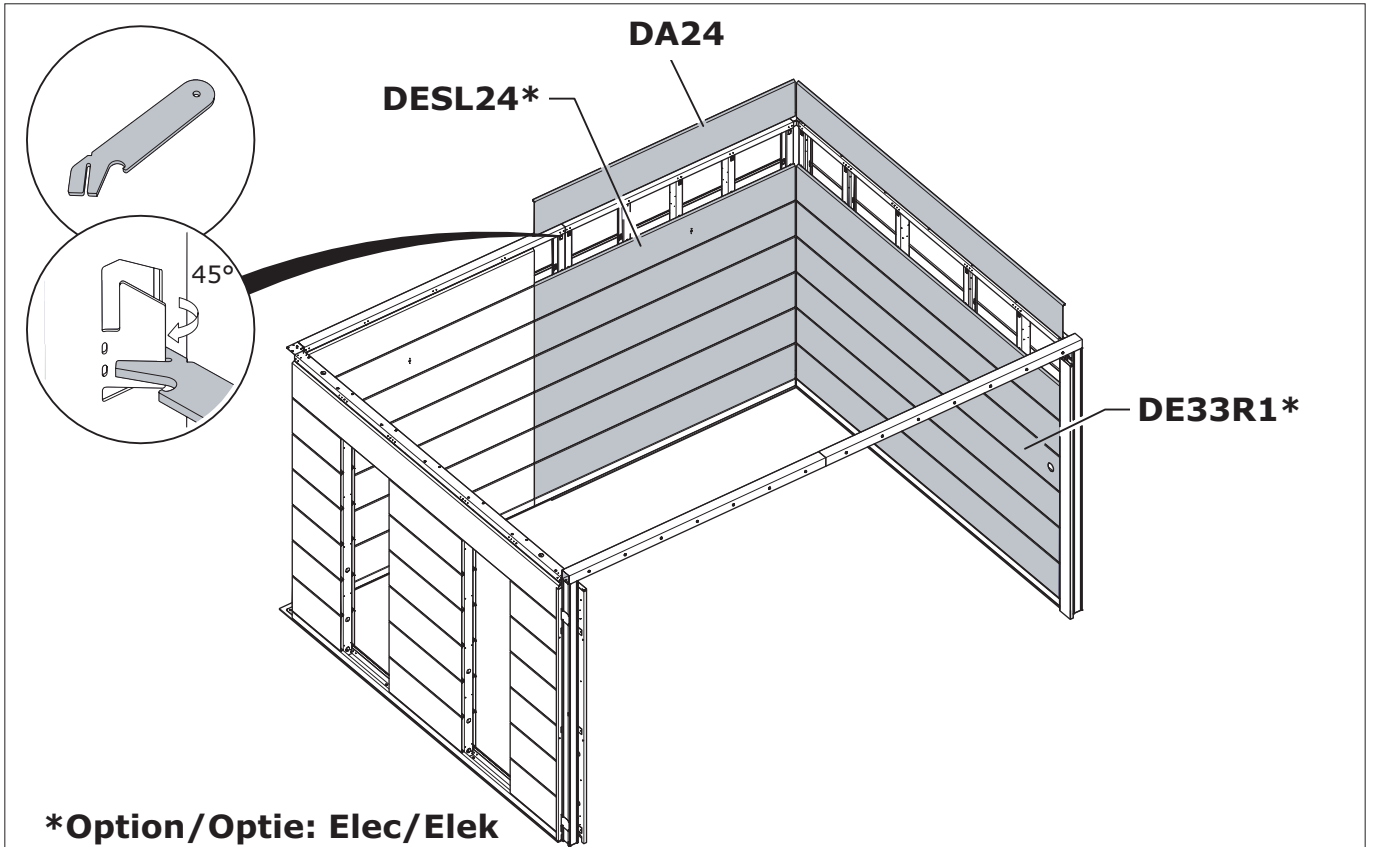

B/C Paroi / Wand / Wall / Wand

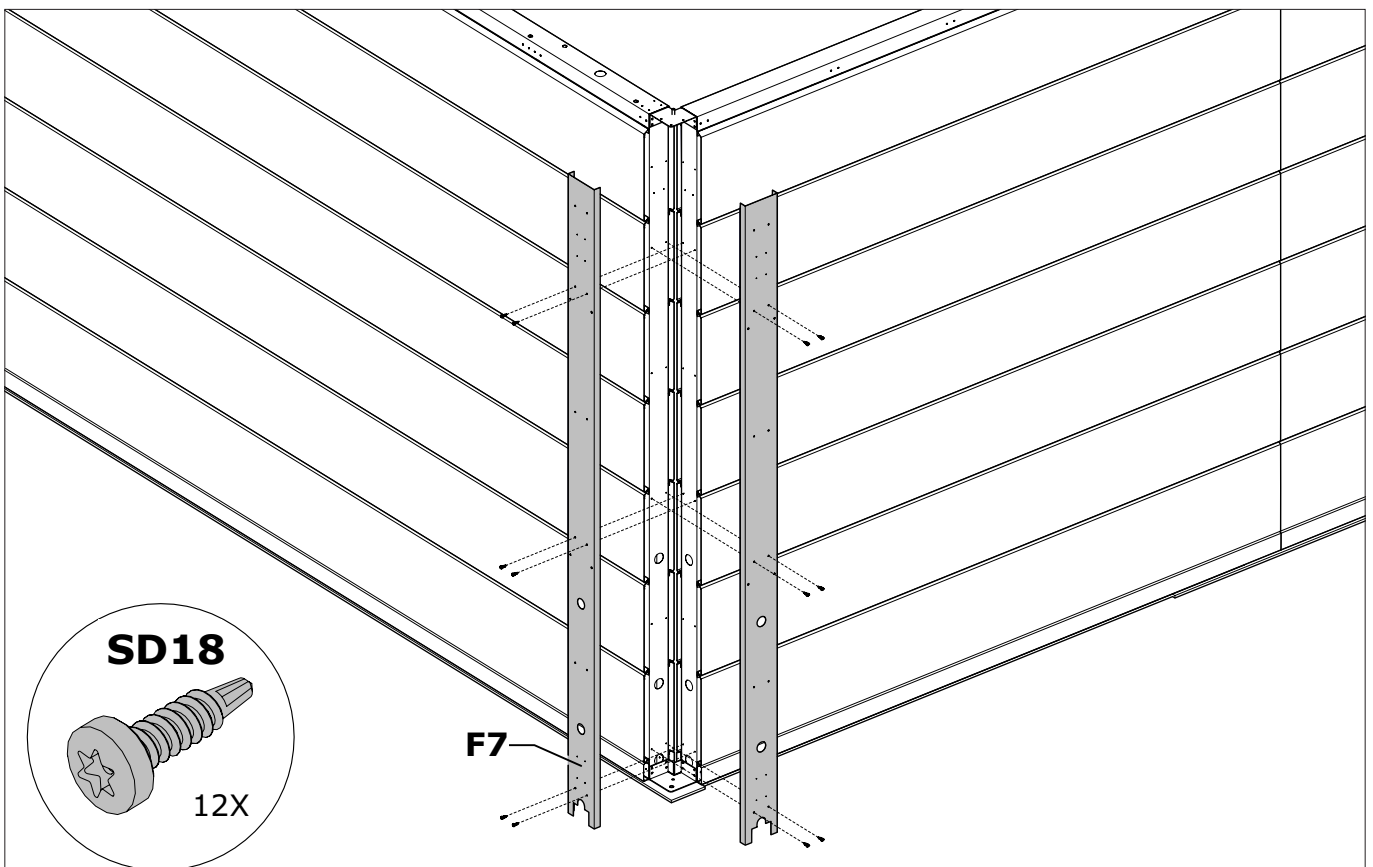

B/C Paroi / Wand / Wall / Wand

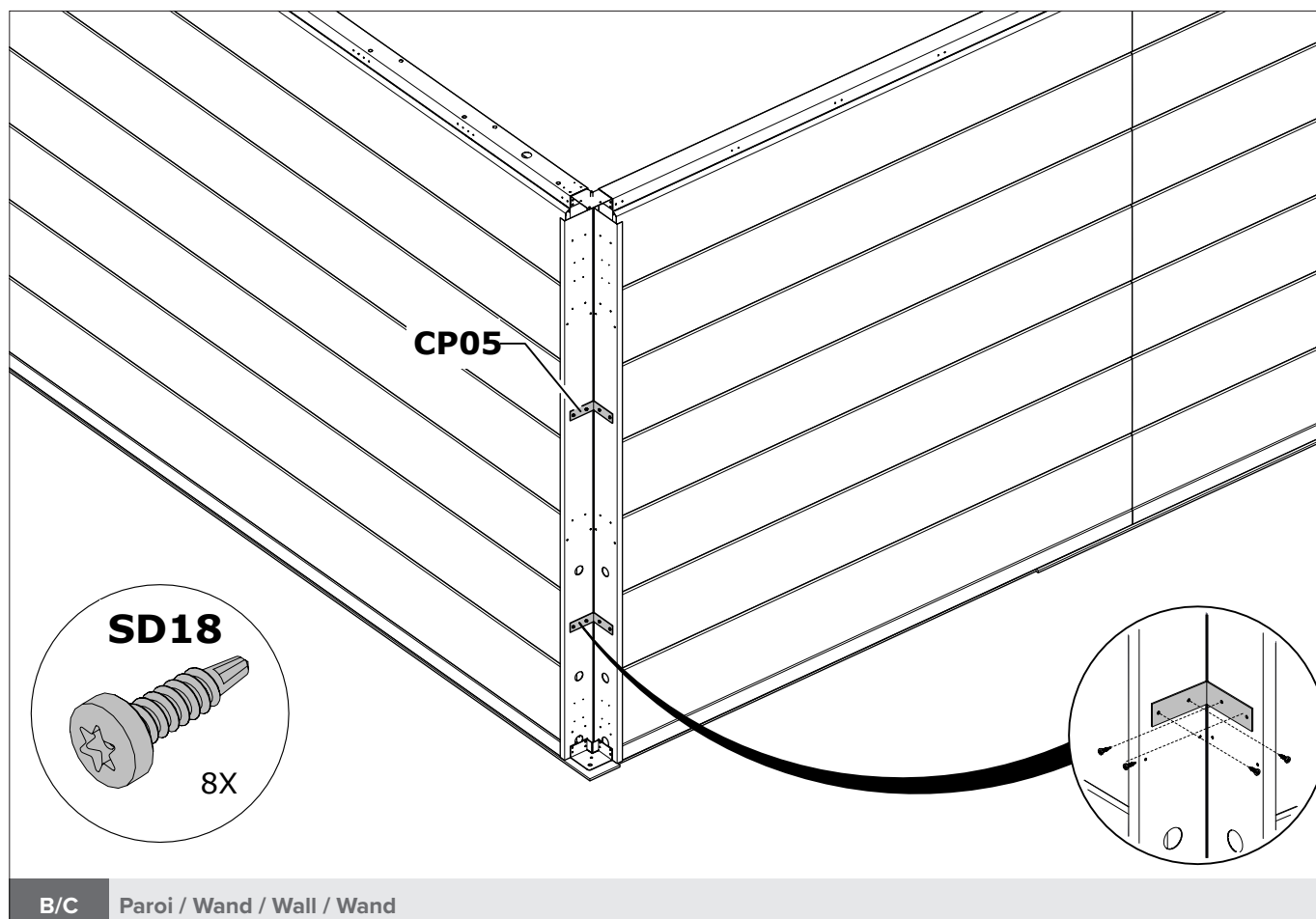
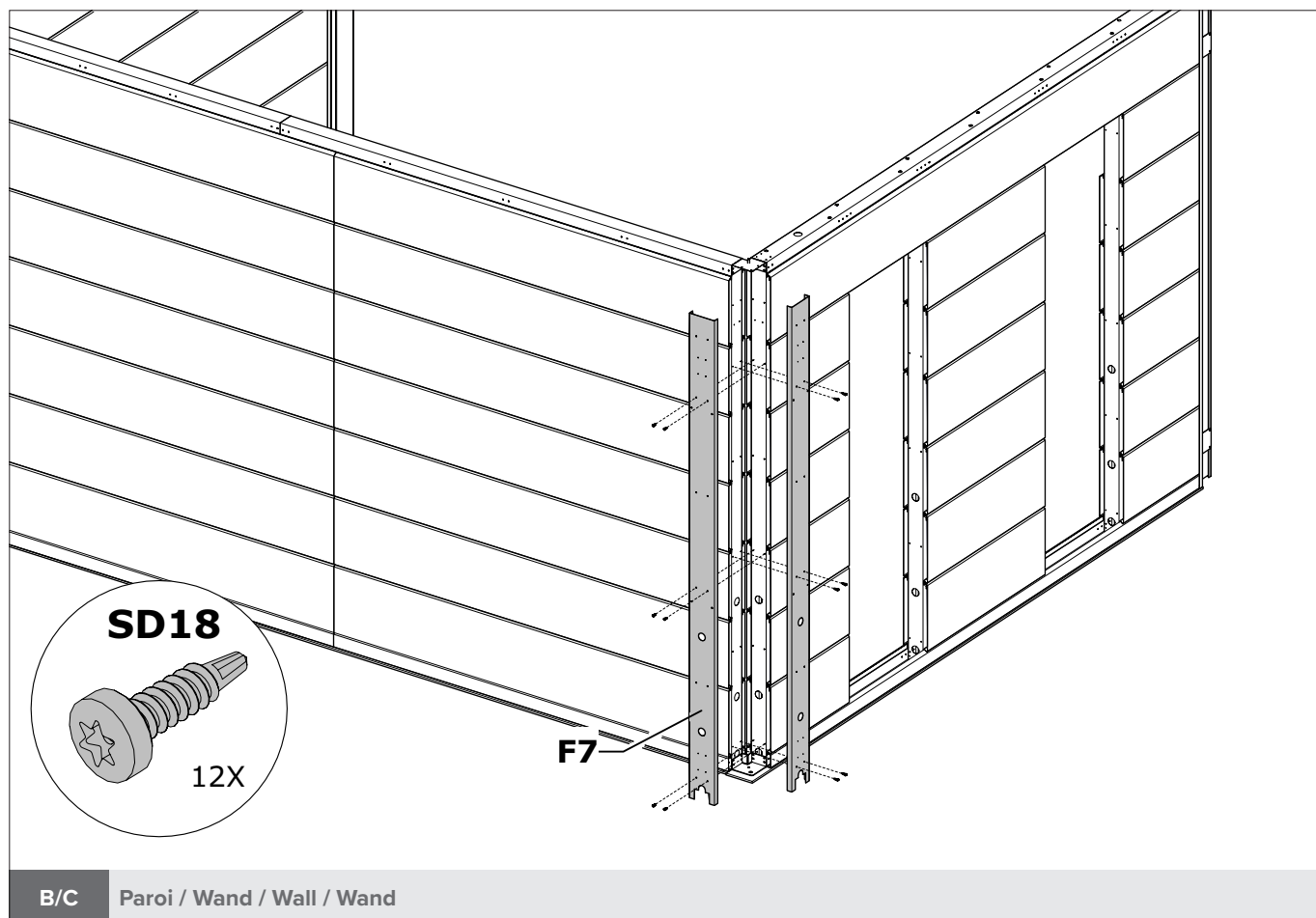

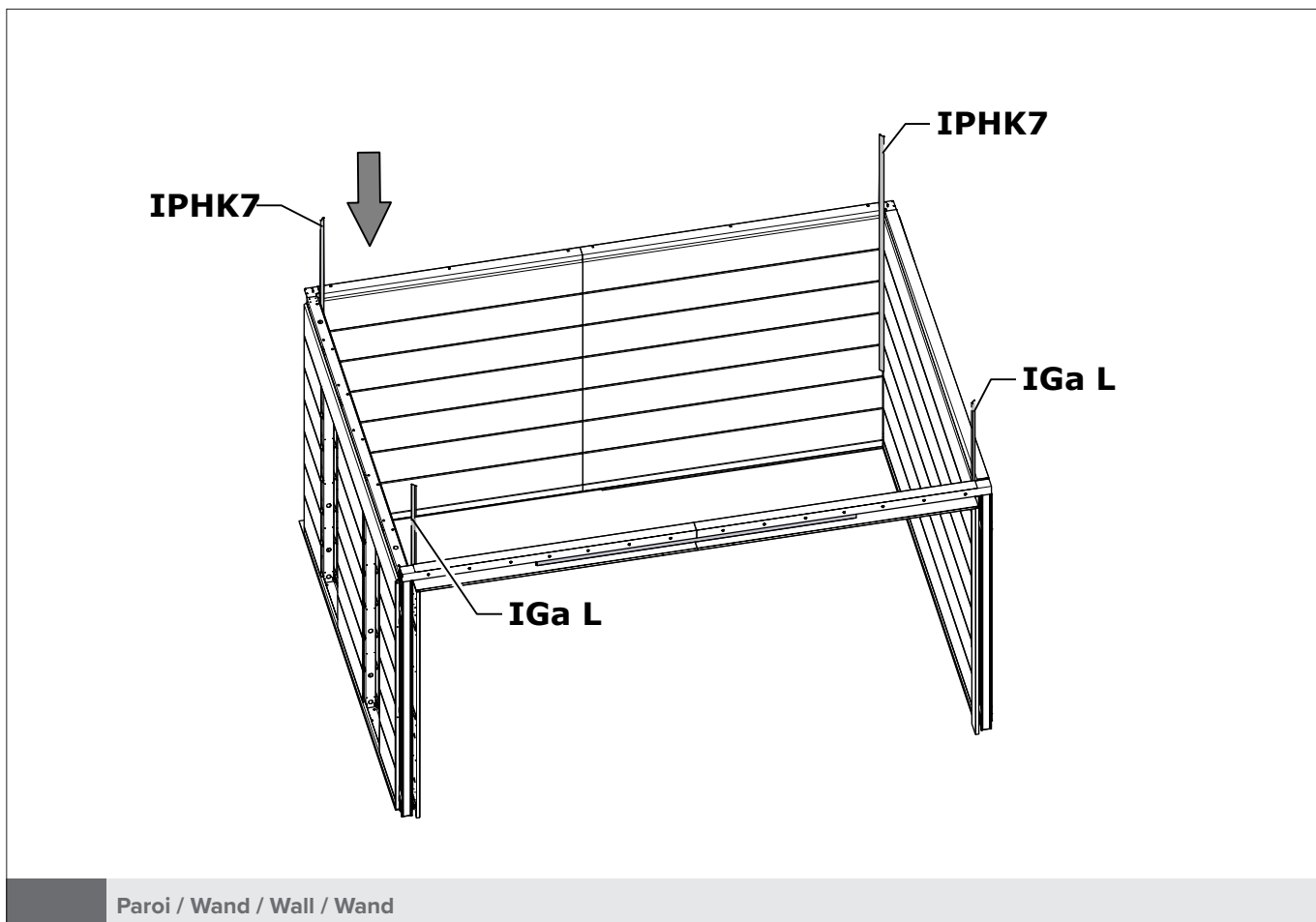
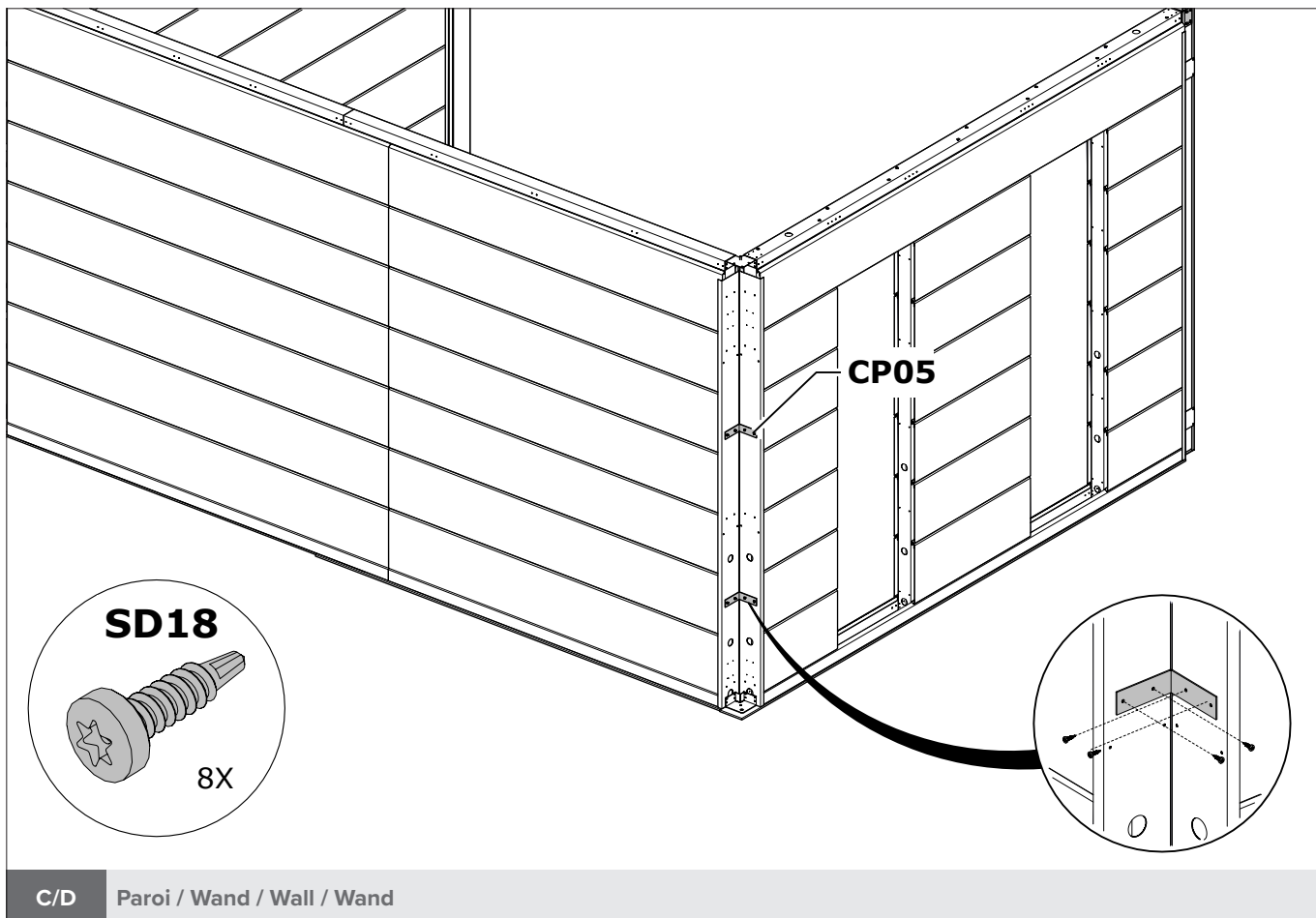

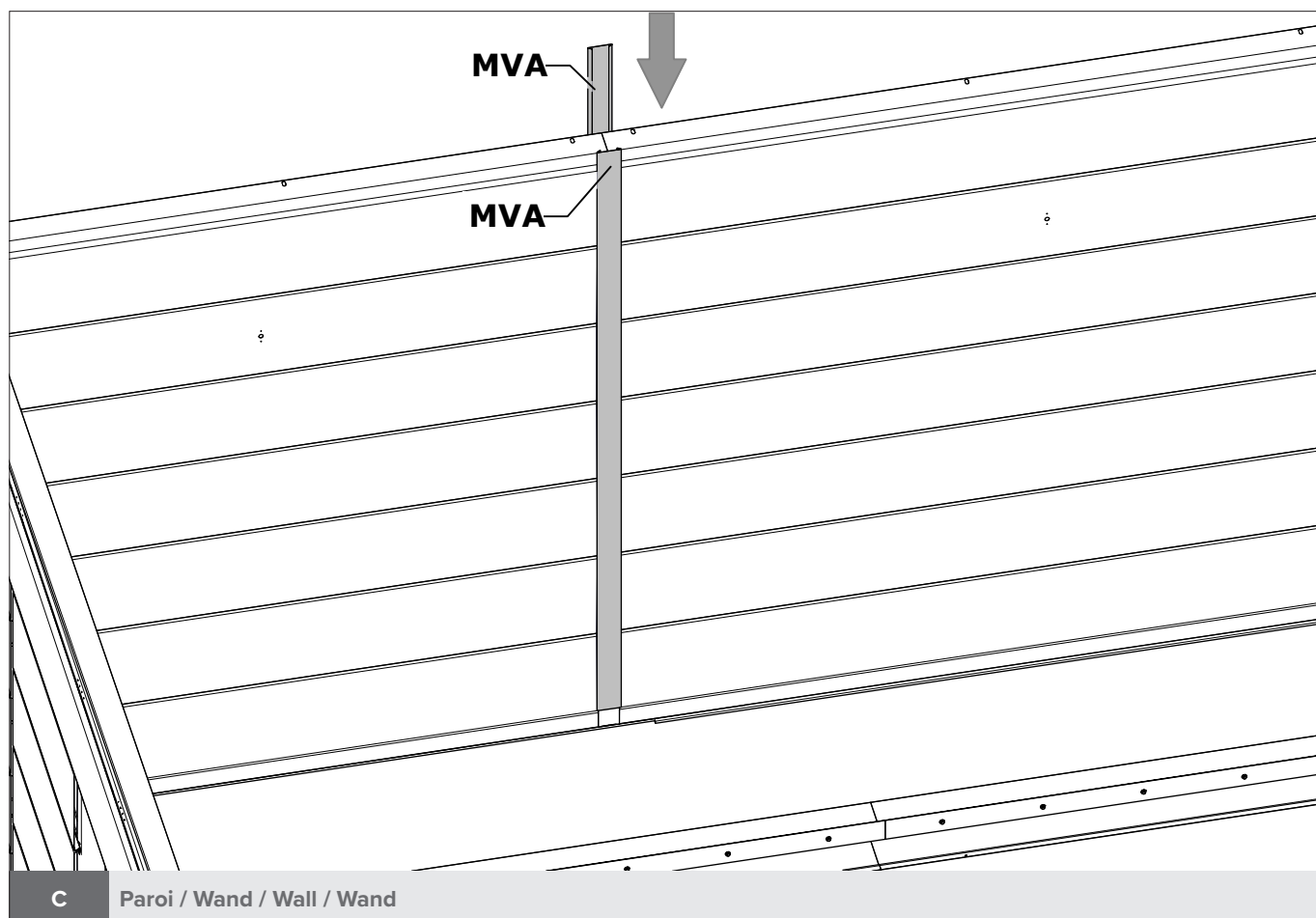
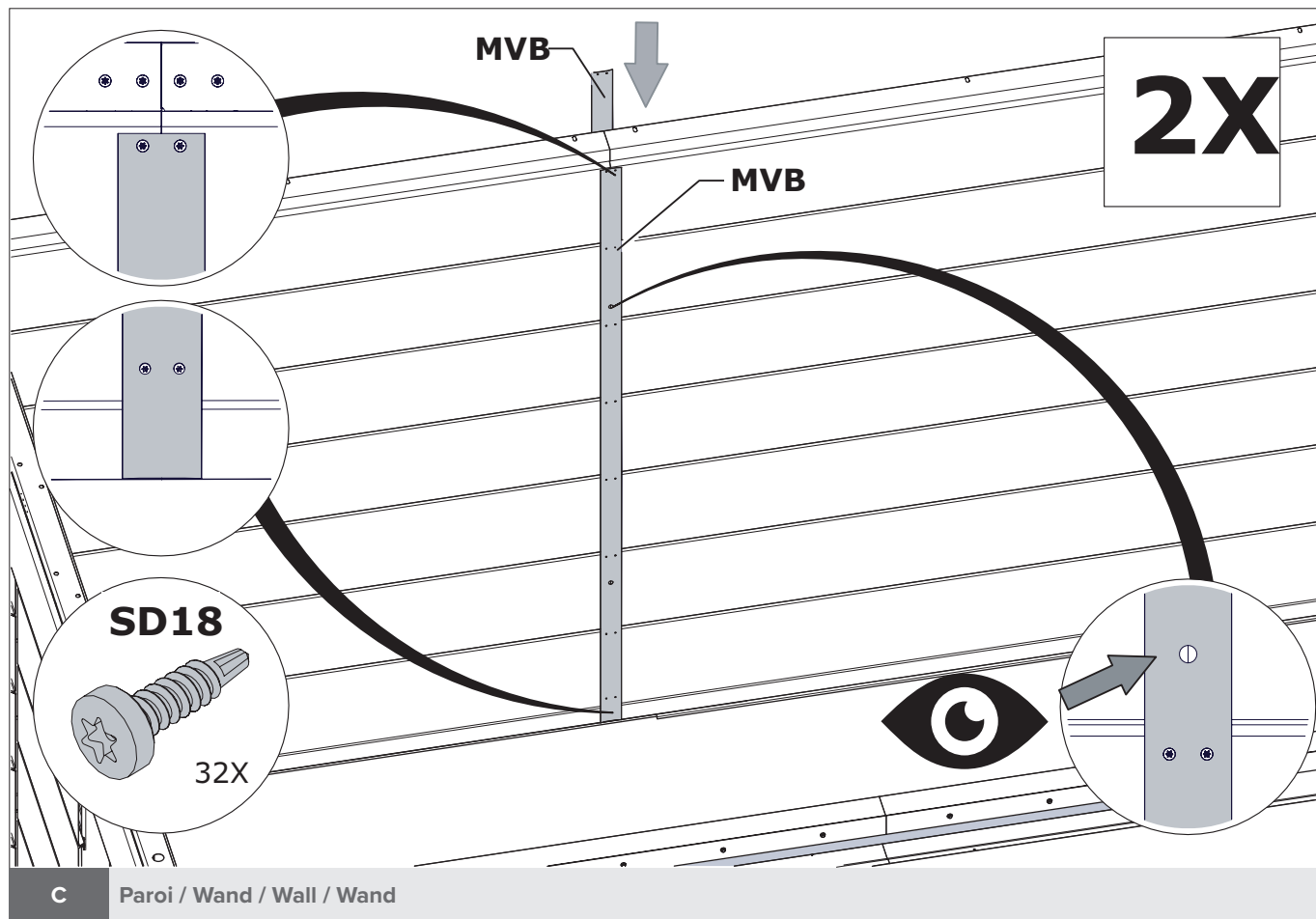

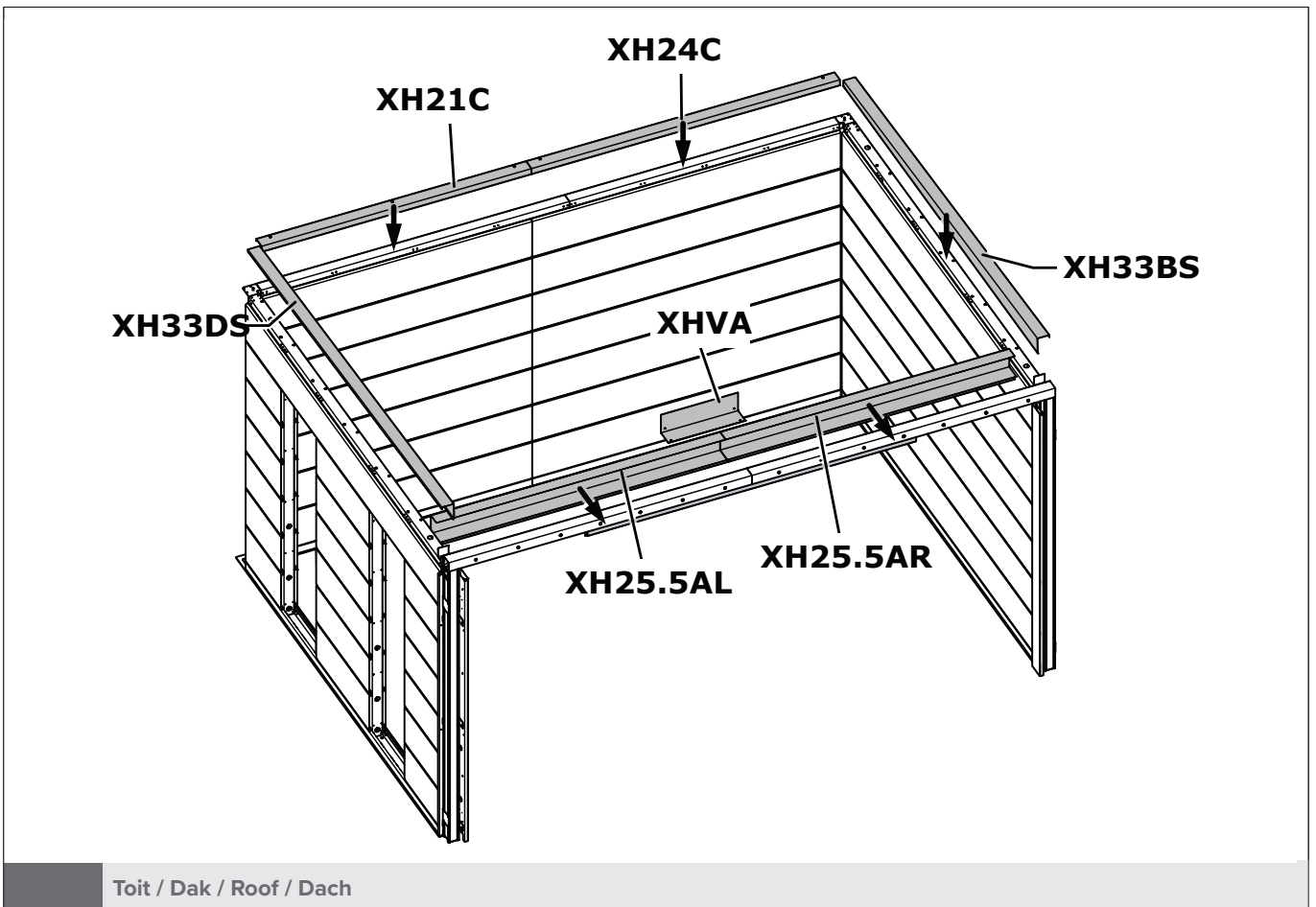
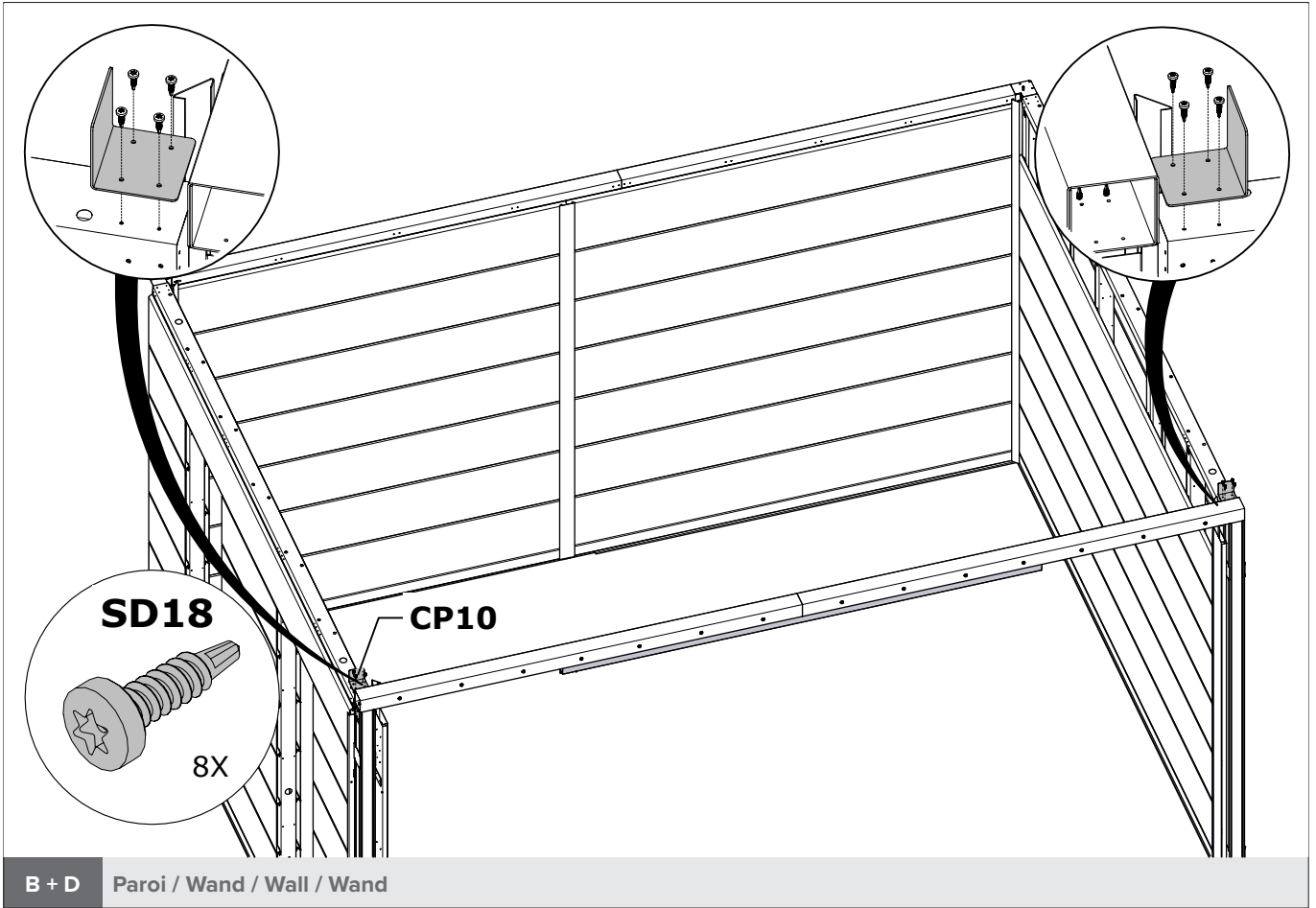

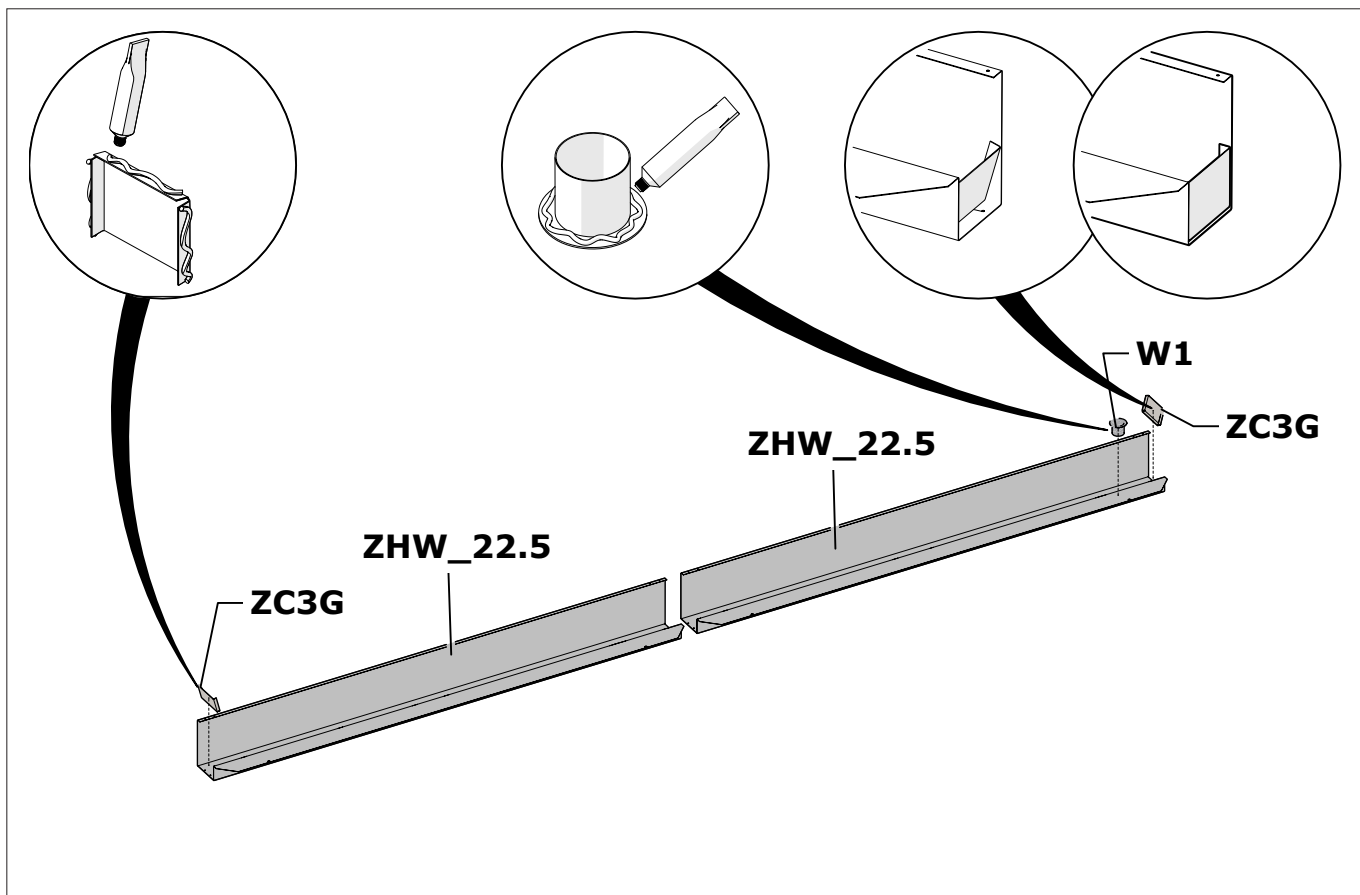

C Toit / Dak / Roof / Dach

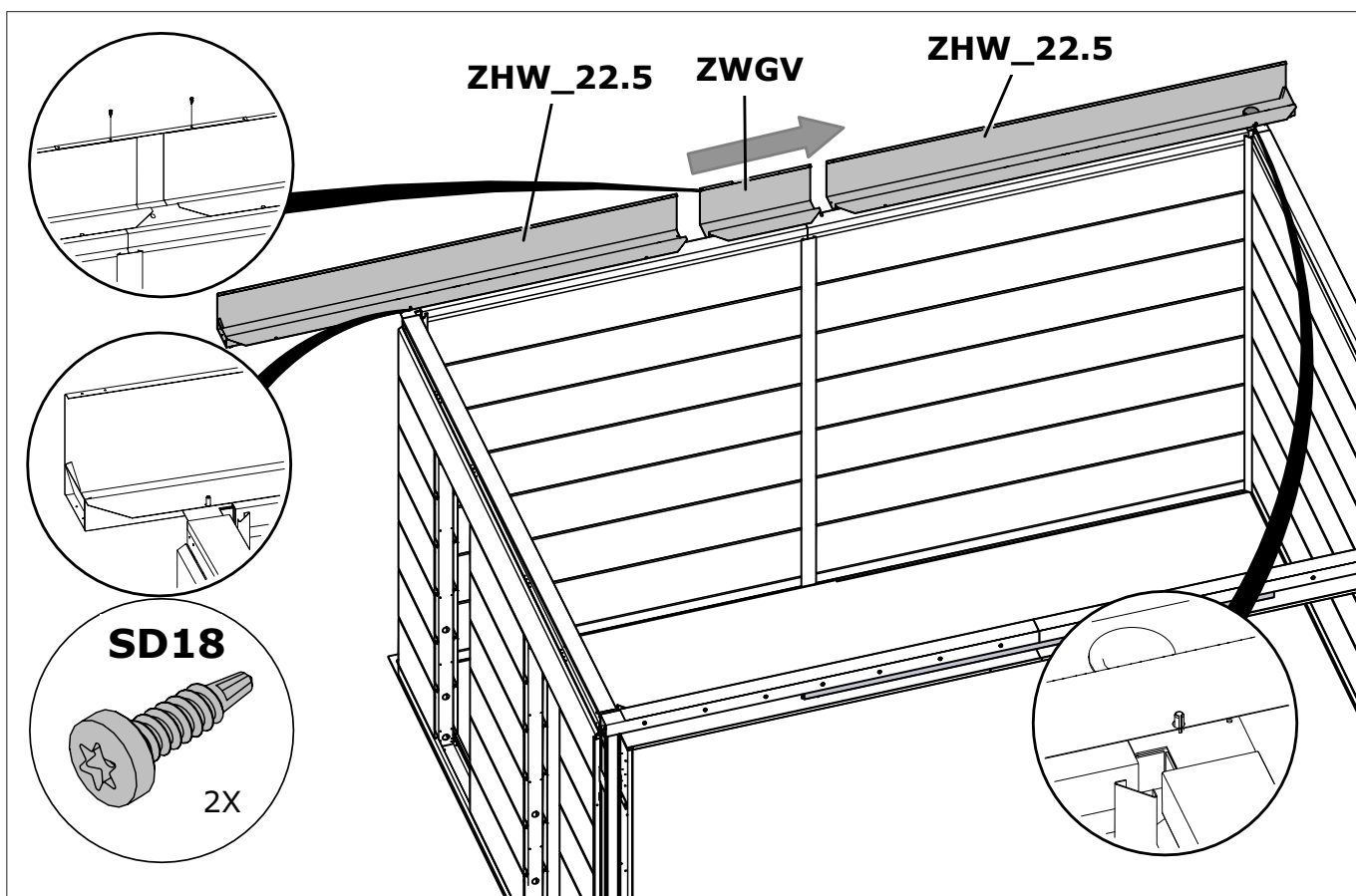

C Toit / Dak / Roof / Dach

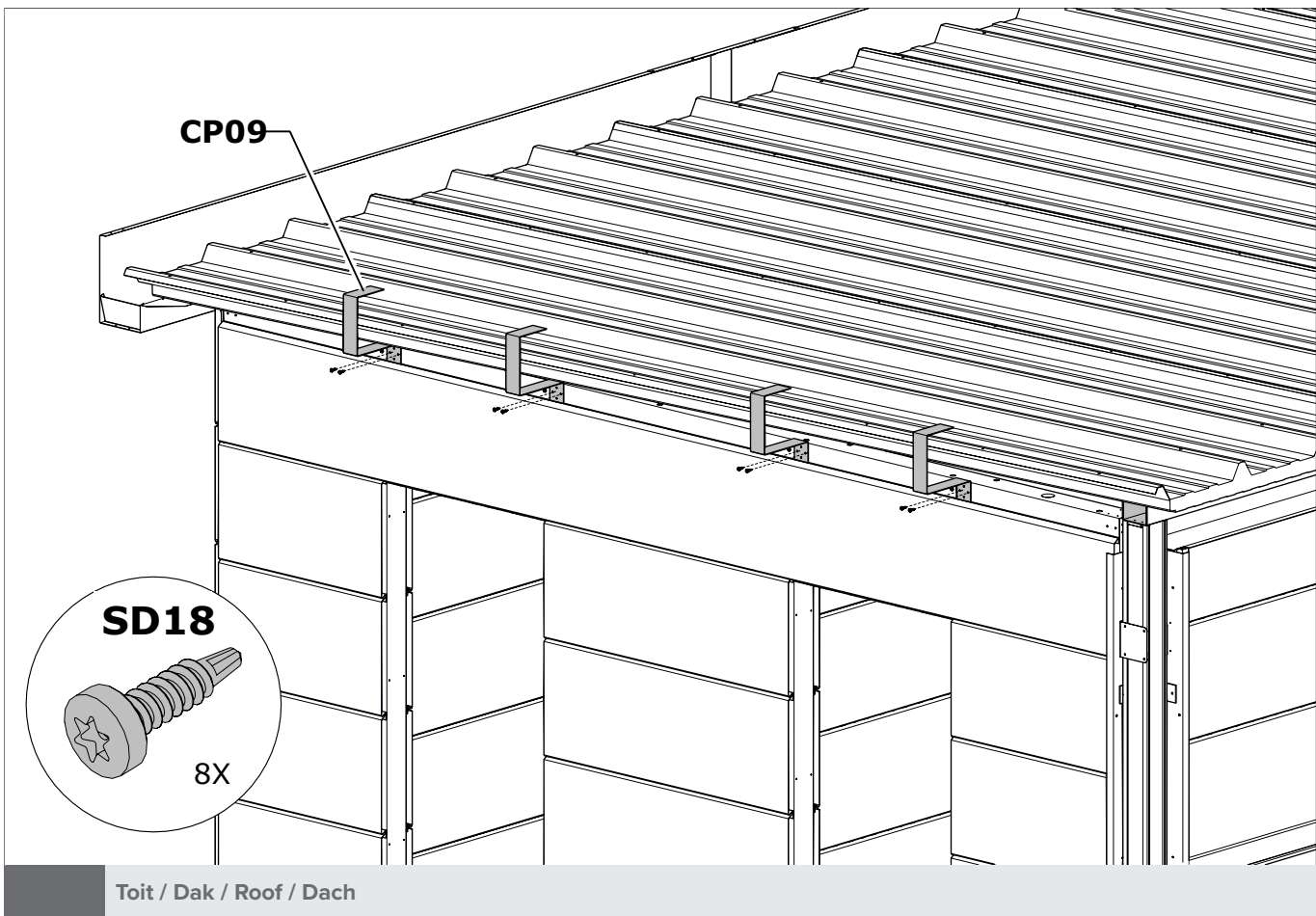
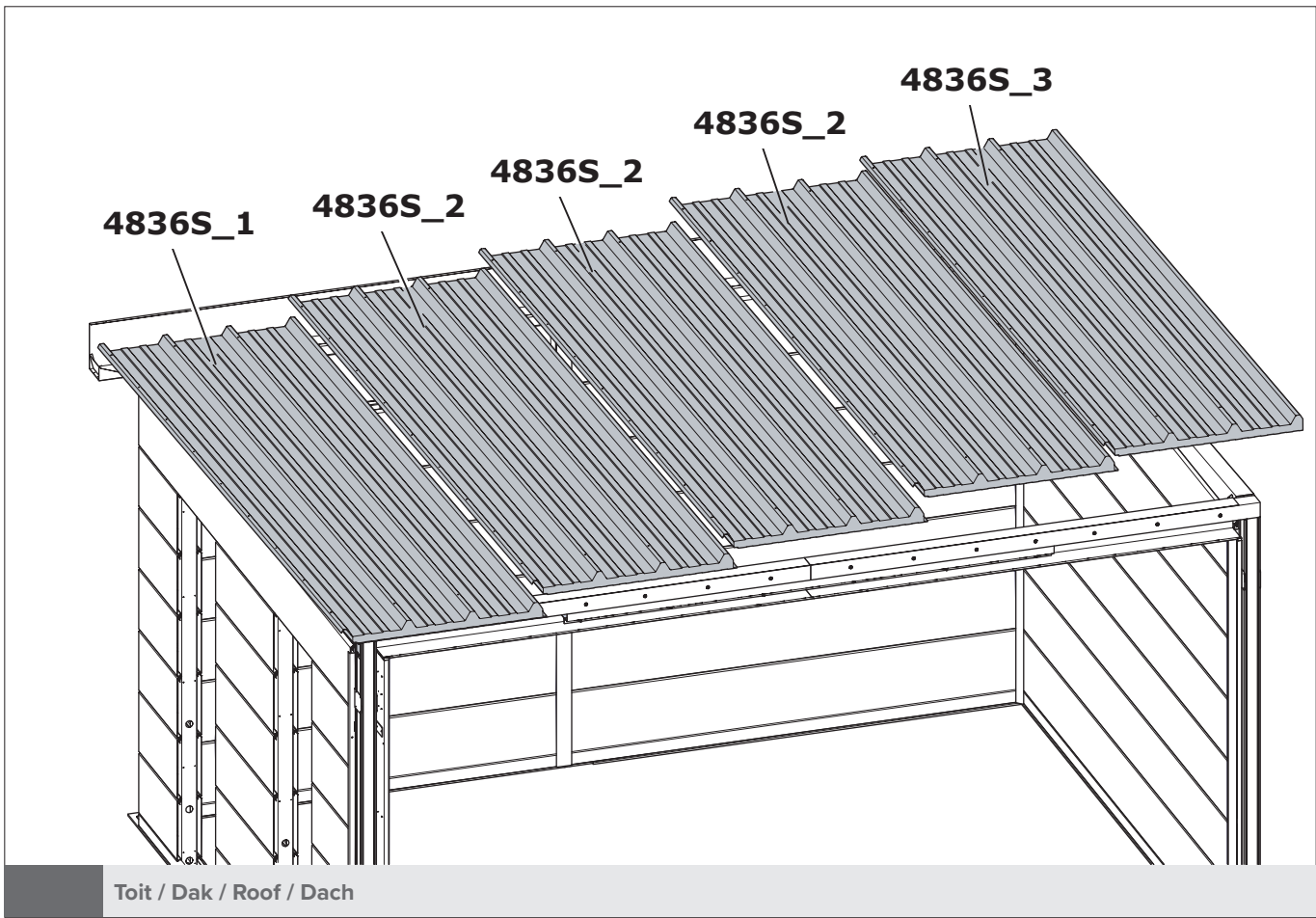

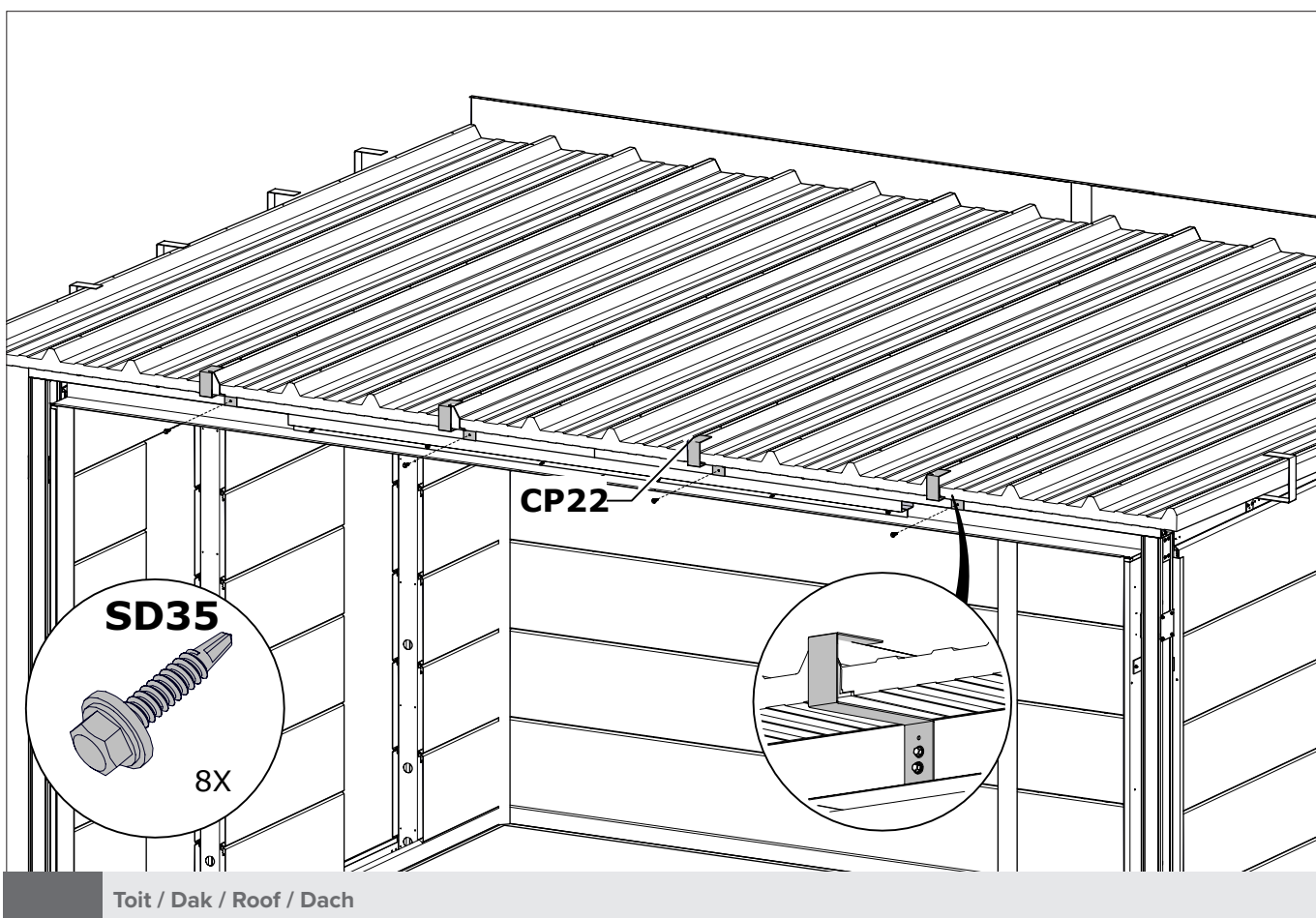
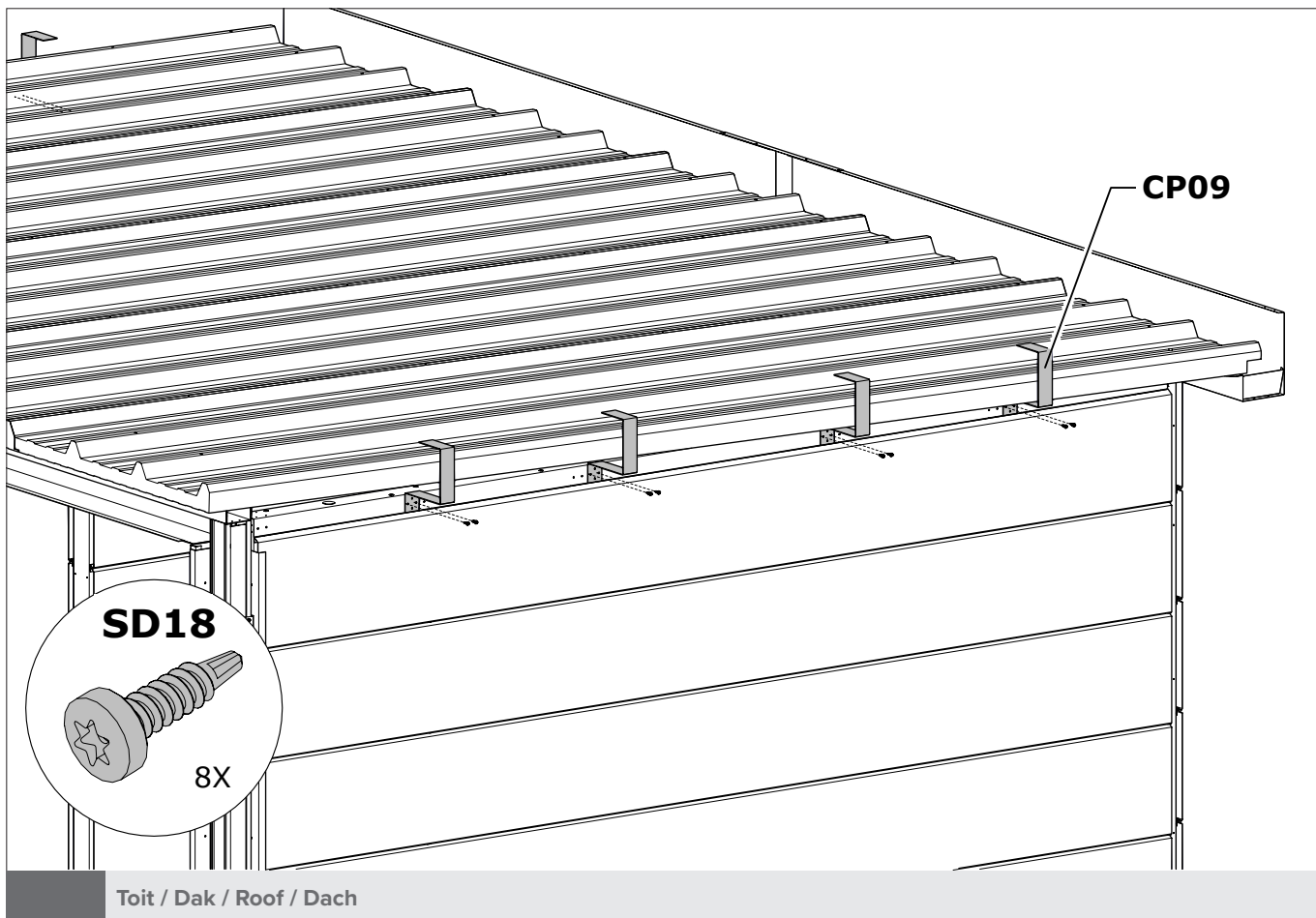

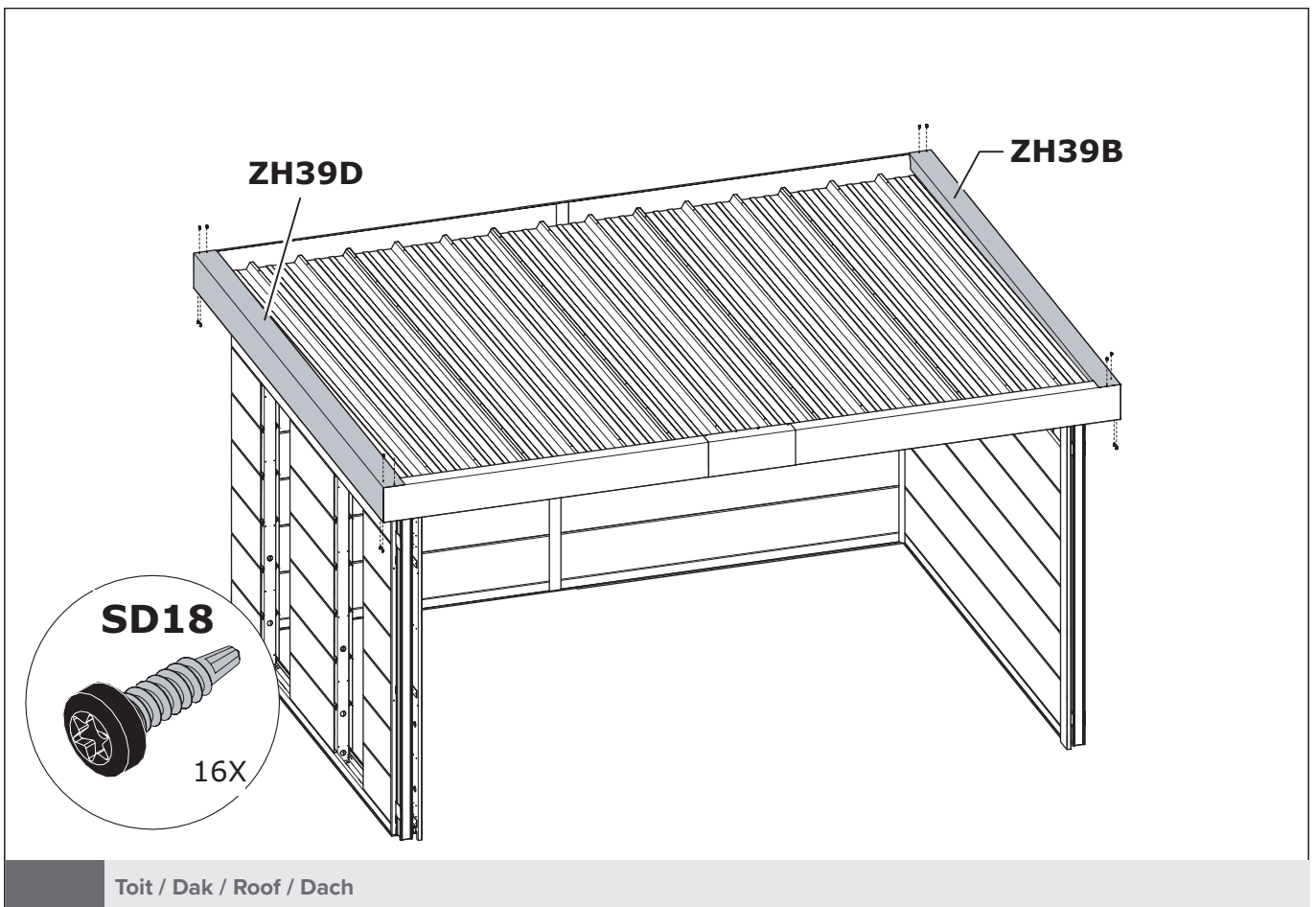
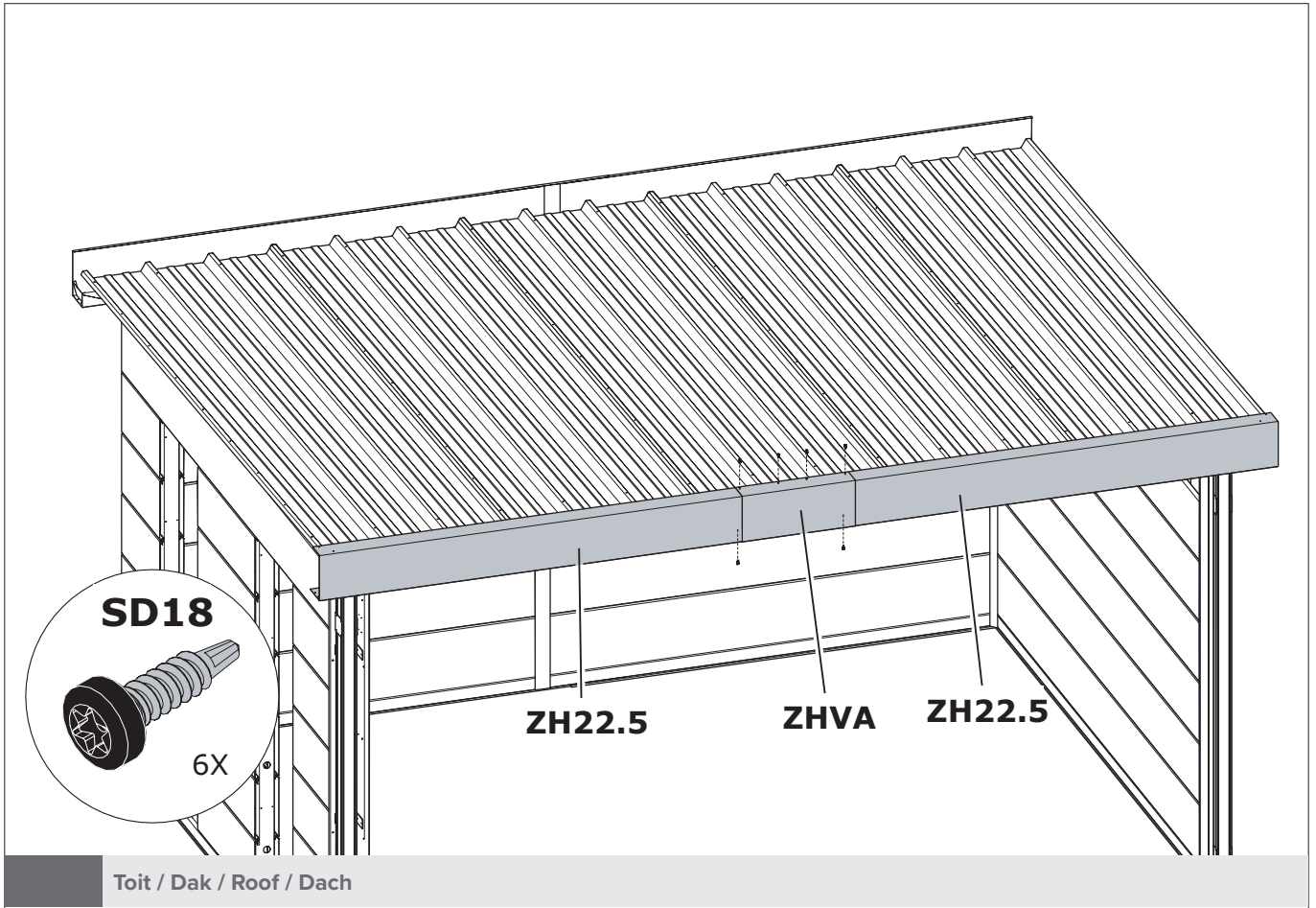

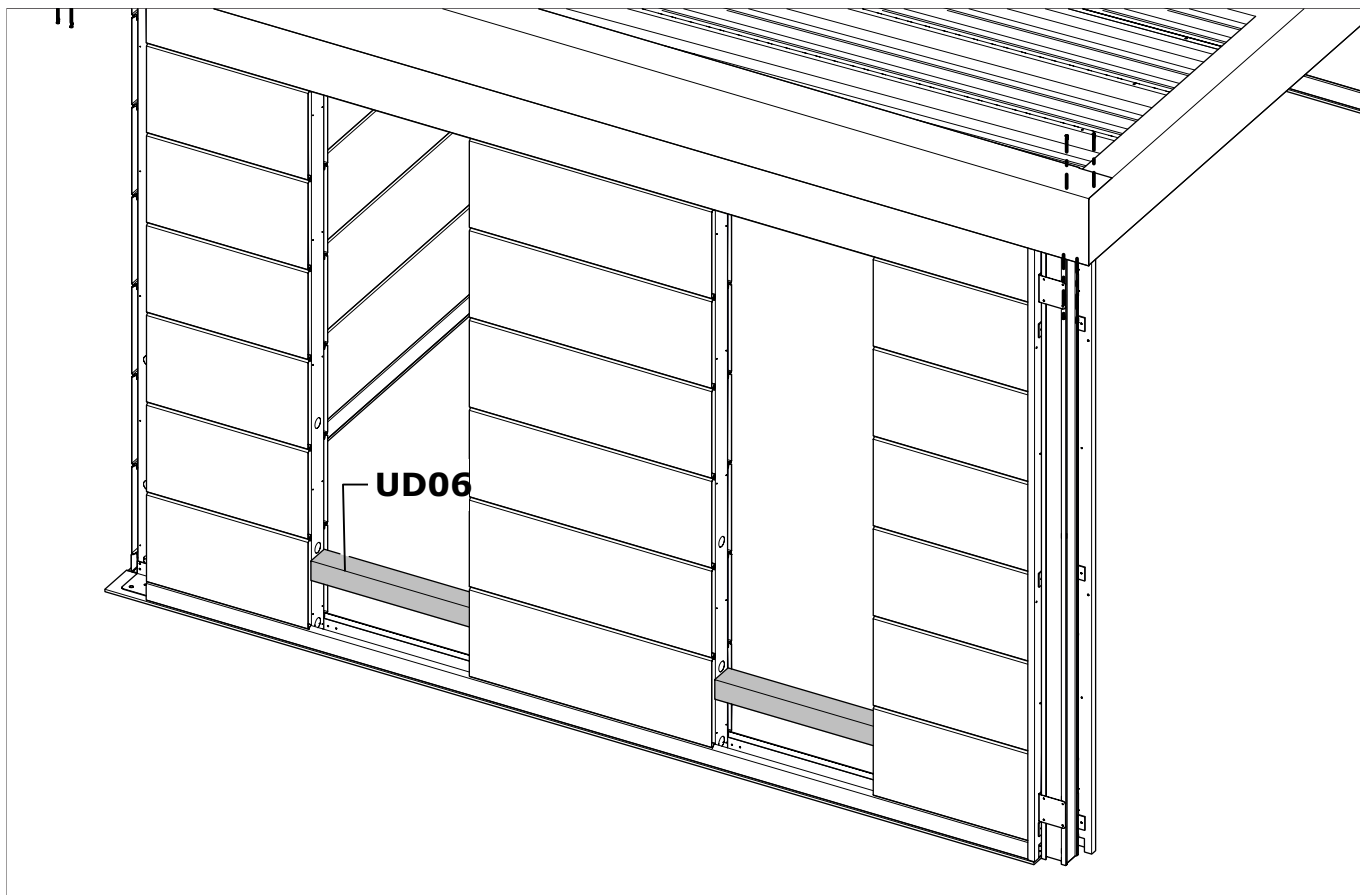

W Fenêtre / Raam / Fenster / Window

Option / Optie / Option / Option

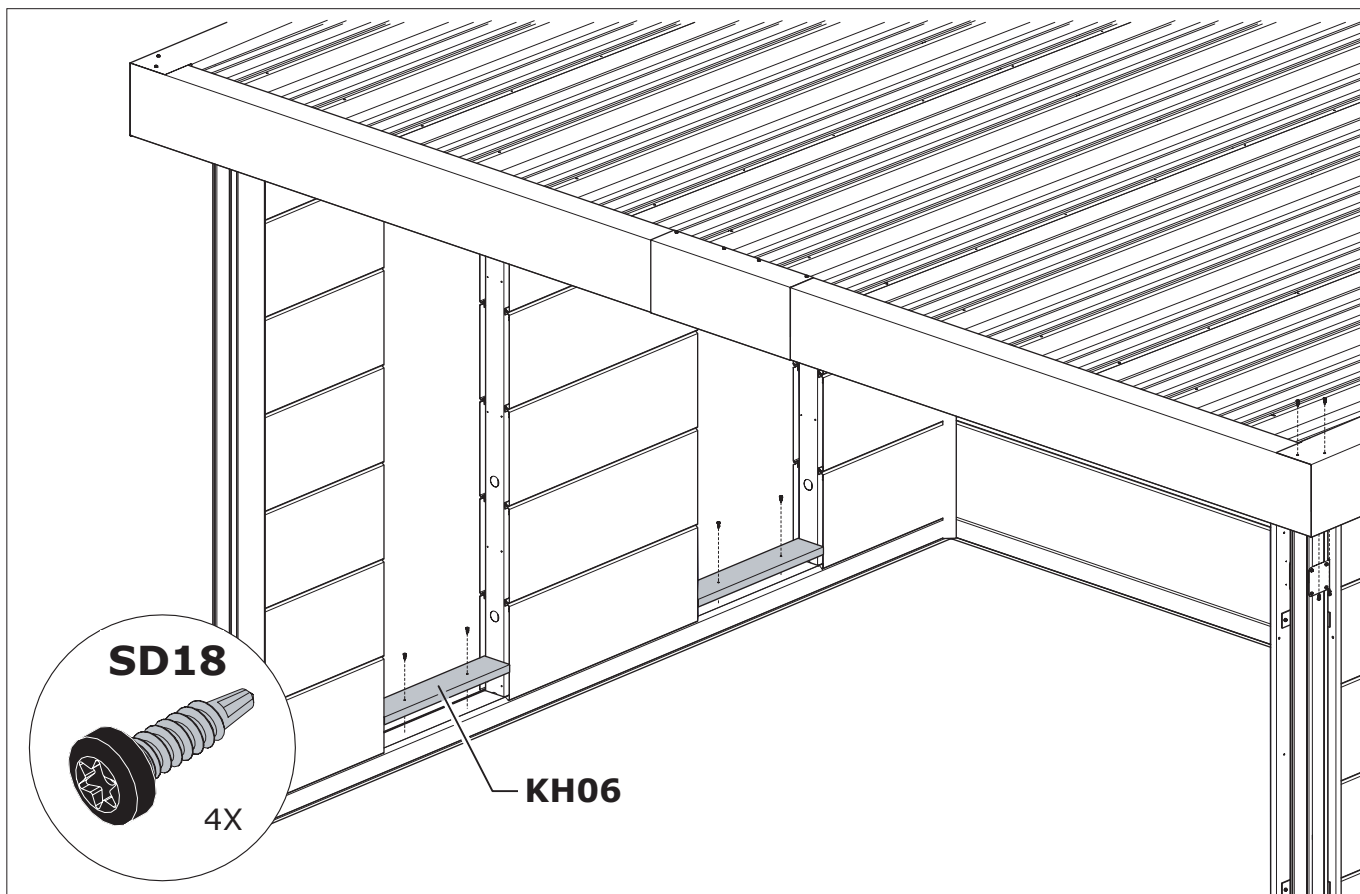

W Fenêtre / Raam / Fenster / Window

Option / Optie / Option / Option

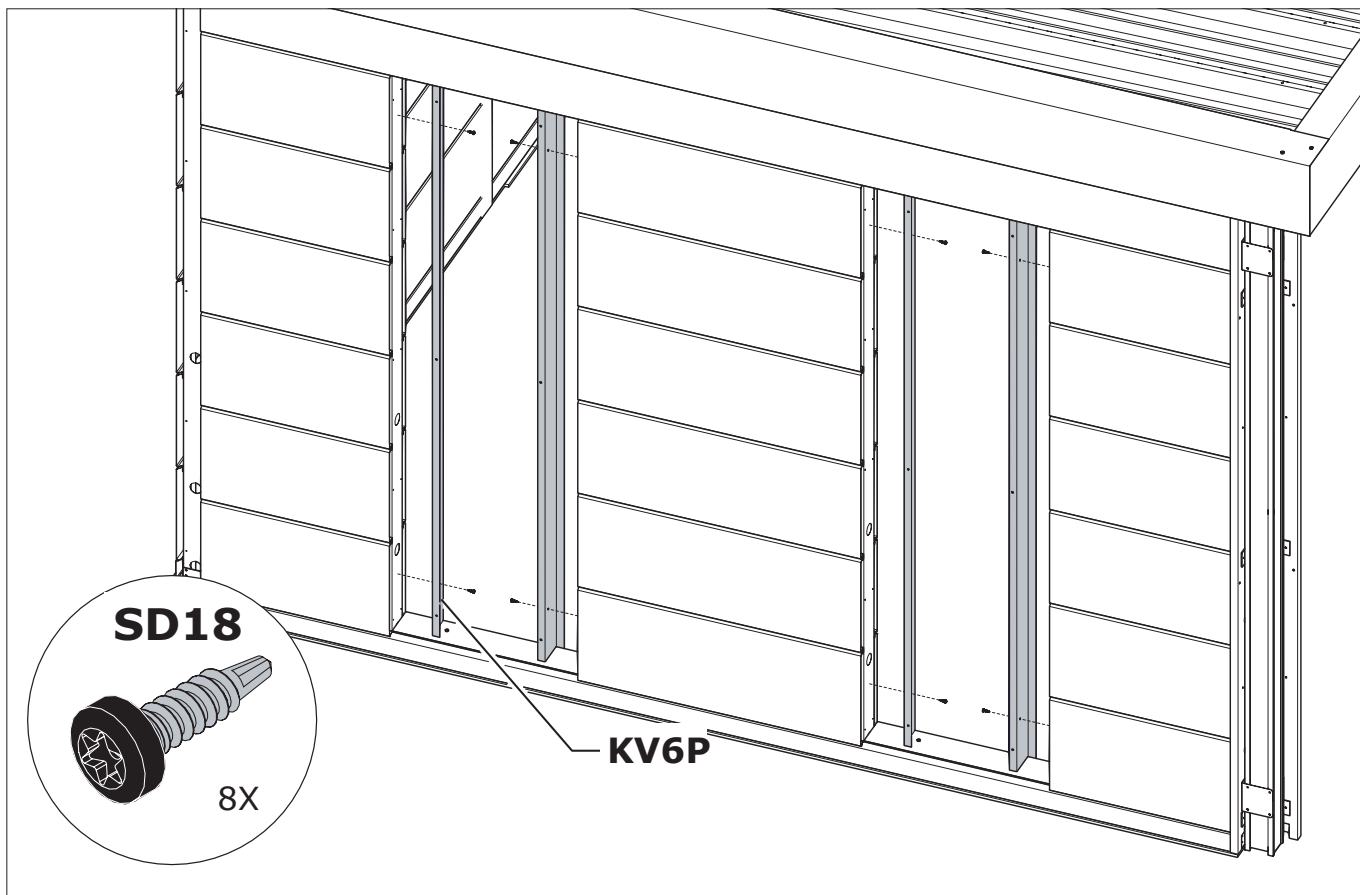

W Fenêtre / Raam / Fenster / Window

Option / Optie / Option / Option

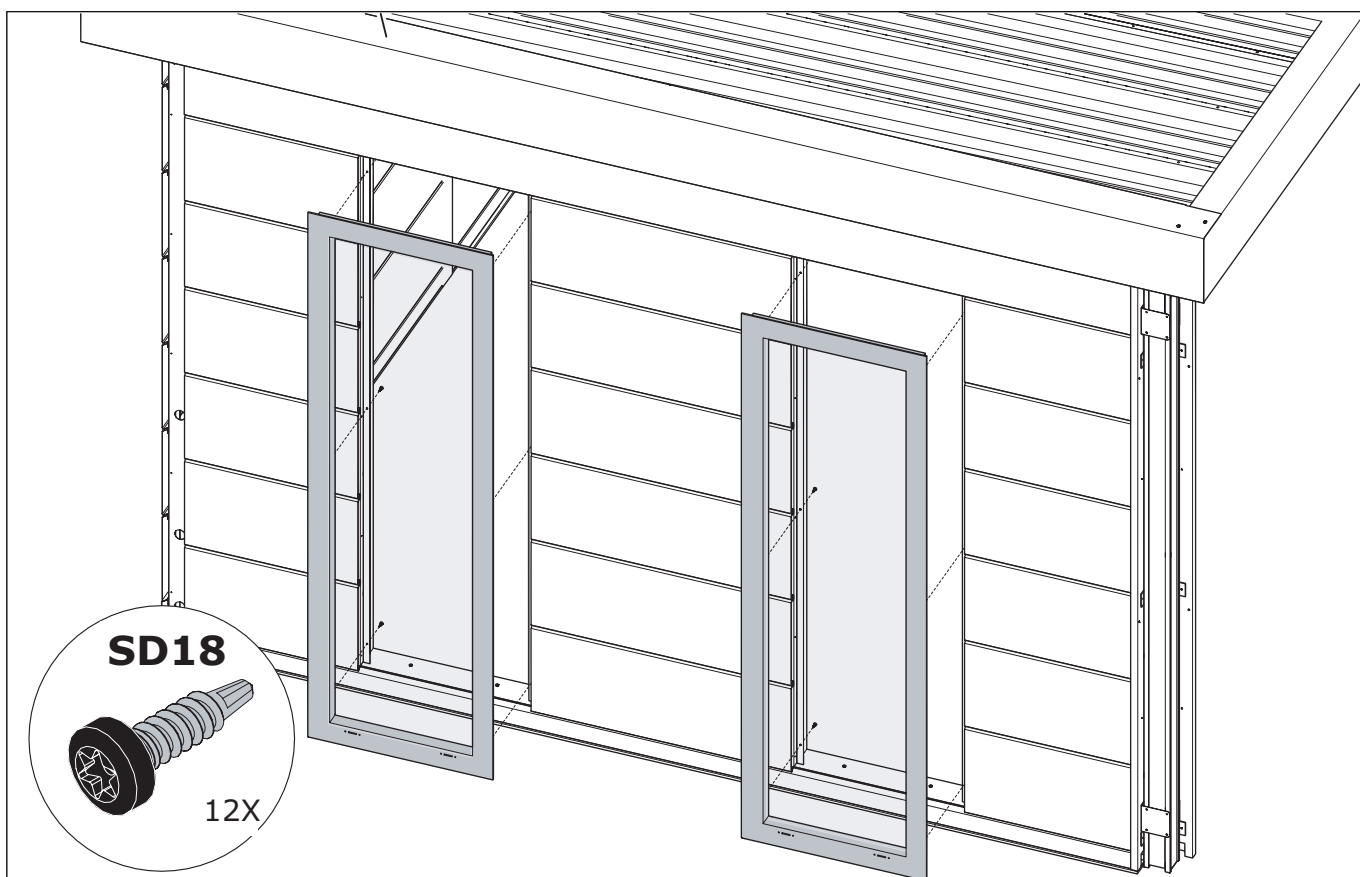

W Fenêtre / Raam / Fenster / Window

Option / Optie / Option / Option

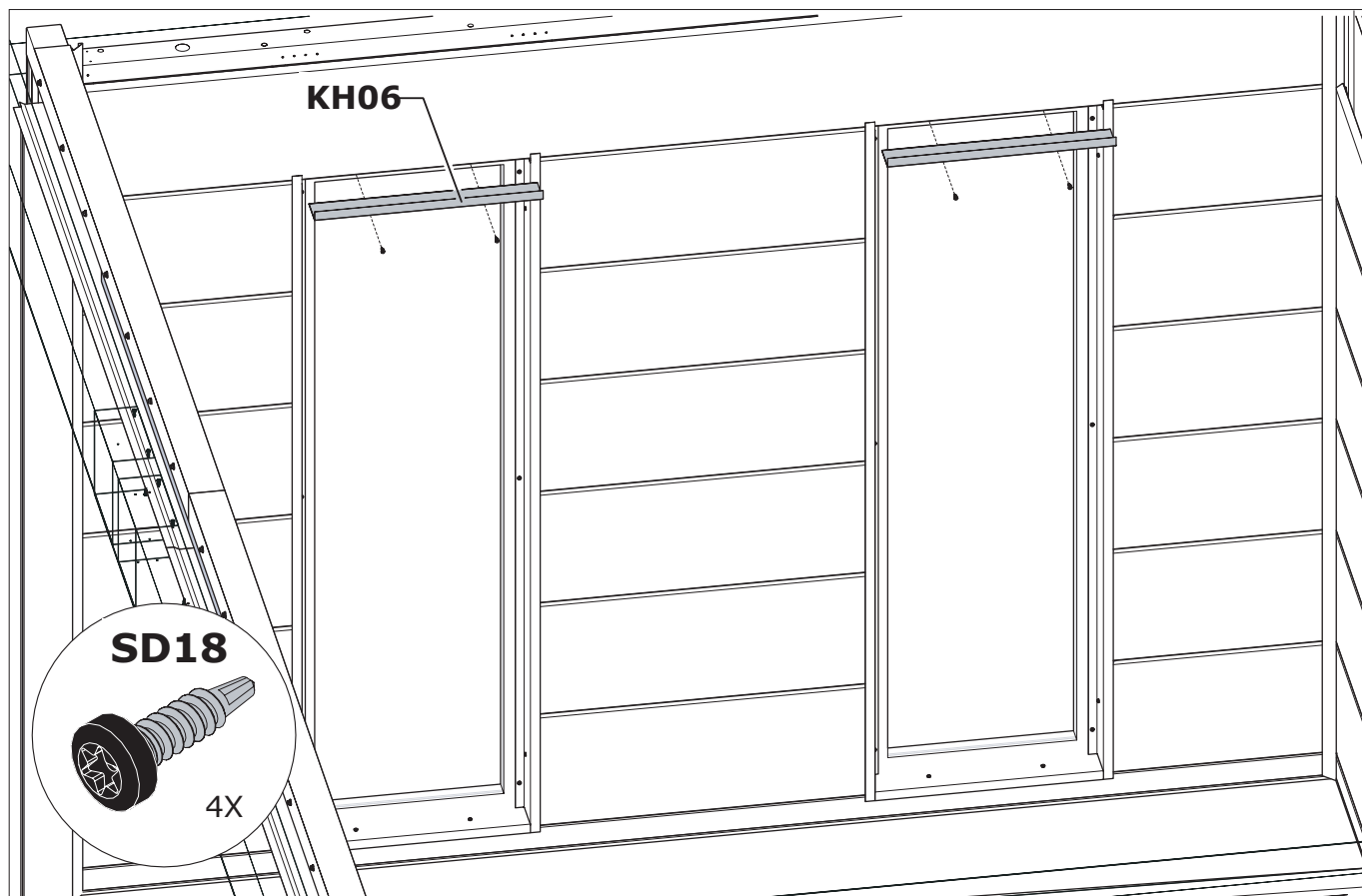

W Fenêtre / Raam / Fenster / Window

Option / Optie / Option / Option

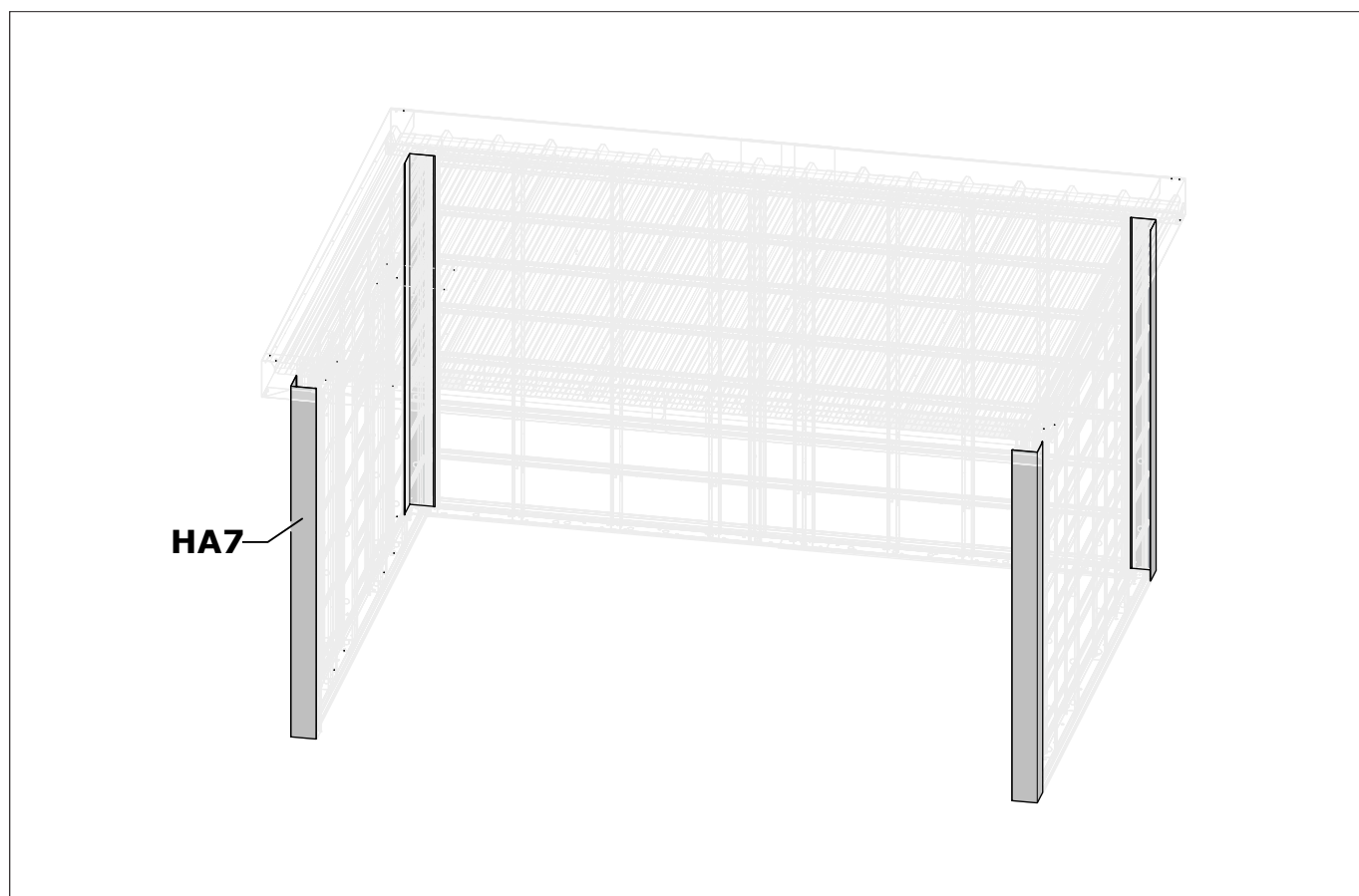

Angle / Hoek / Corner / Ecke

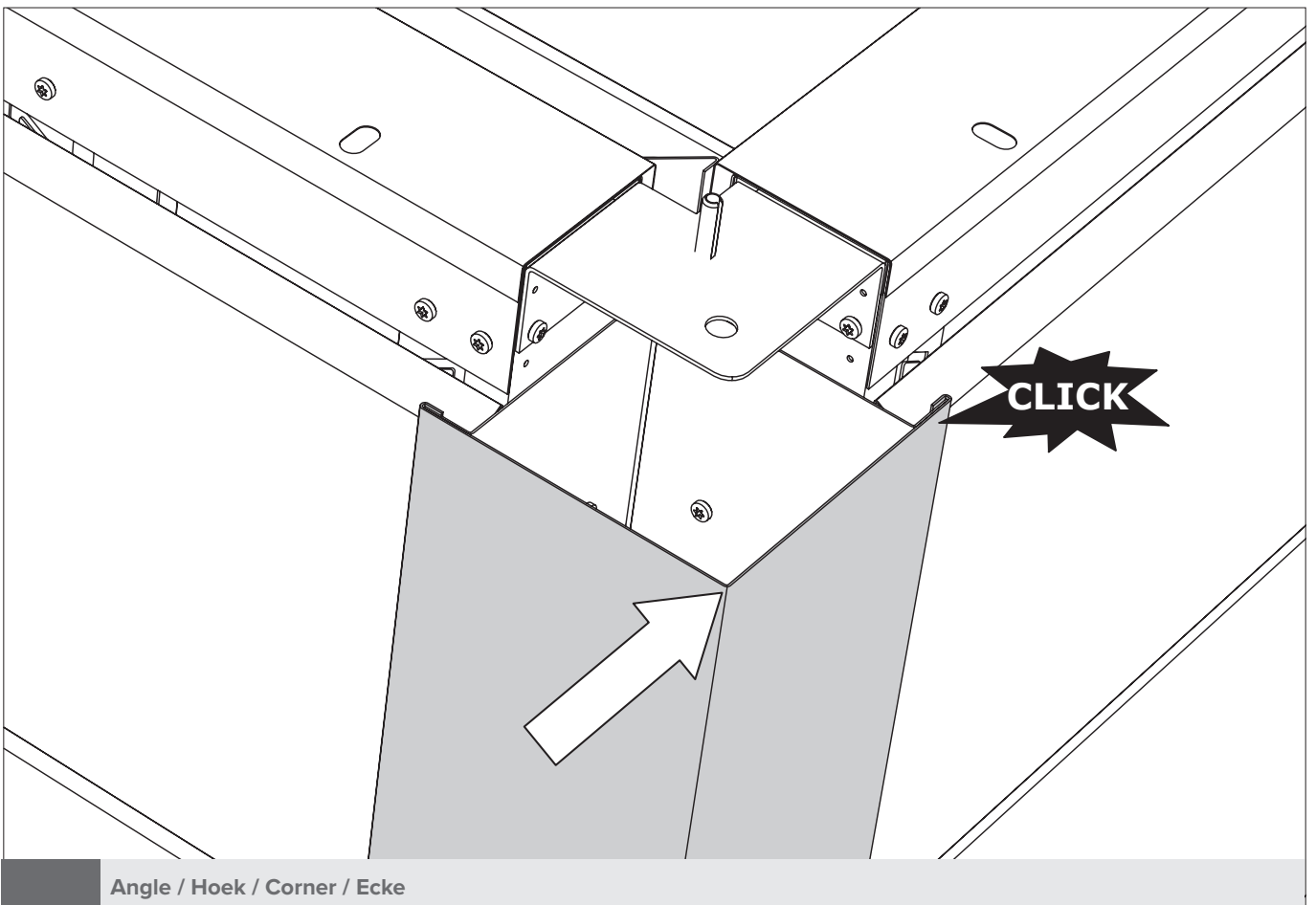
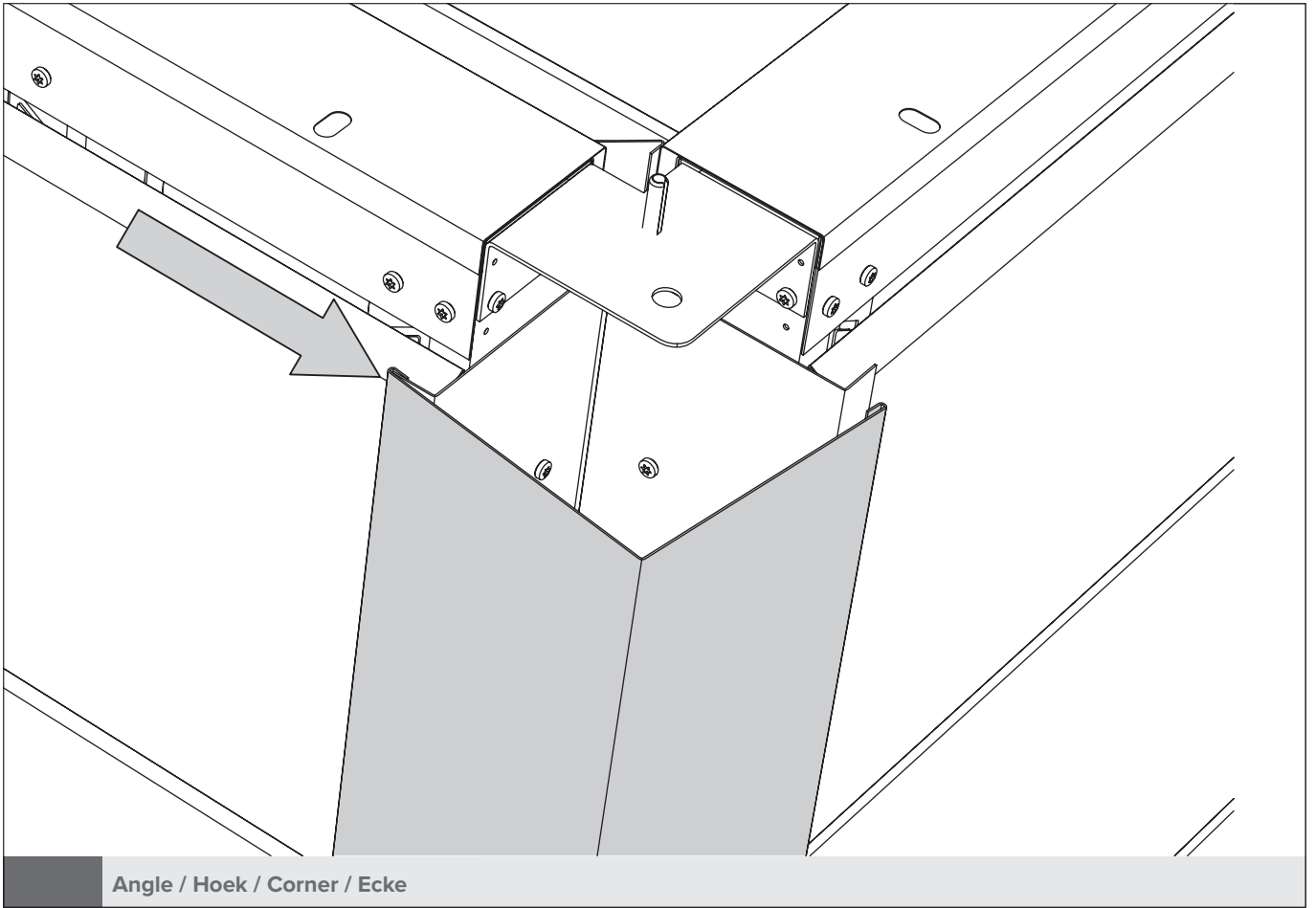

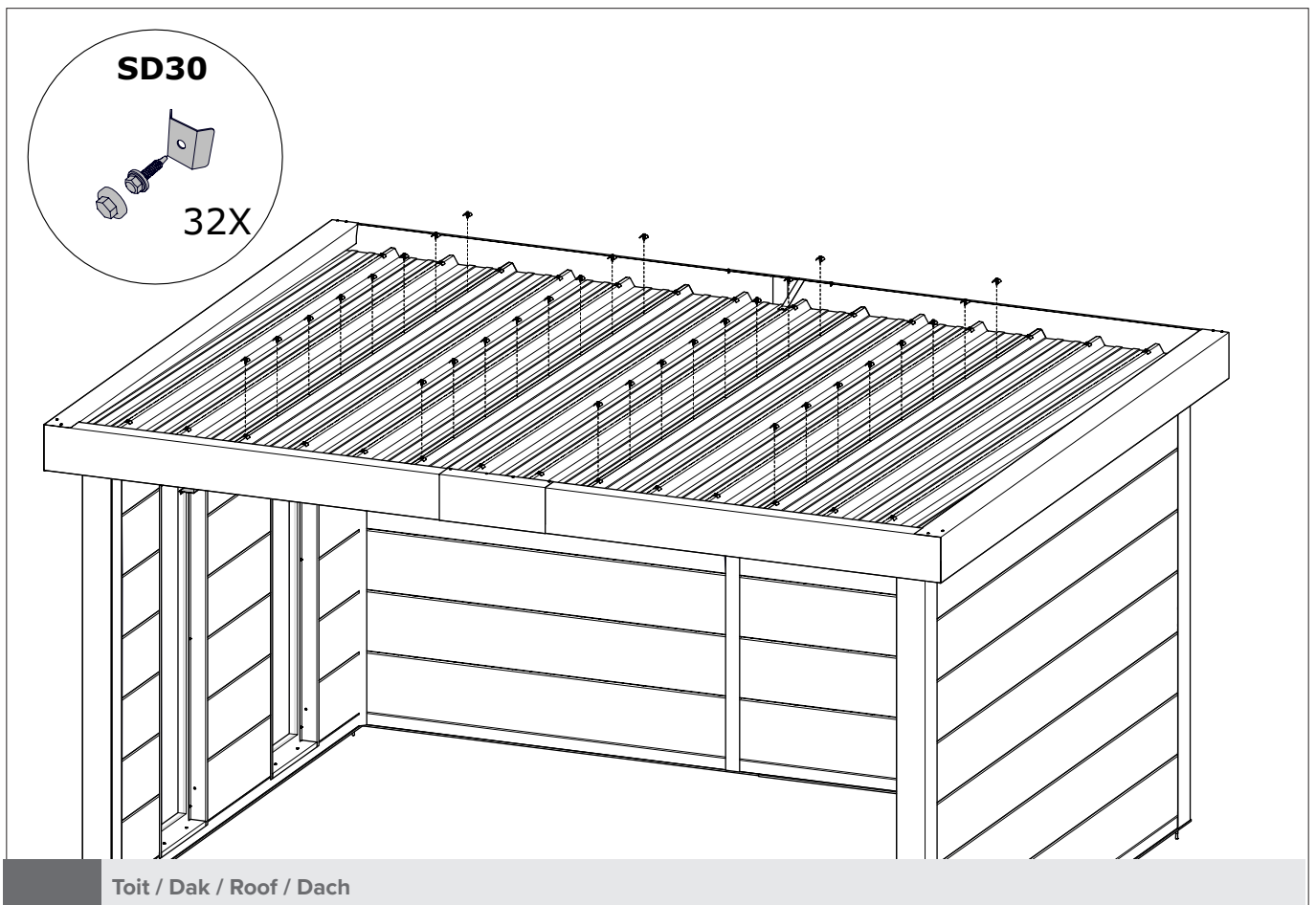
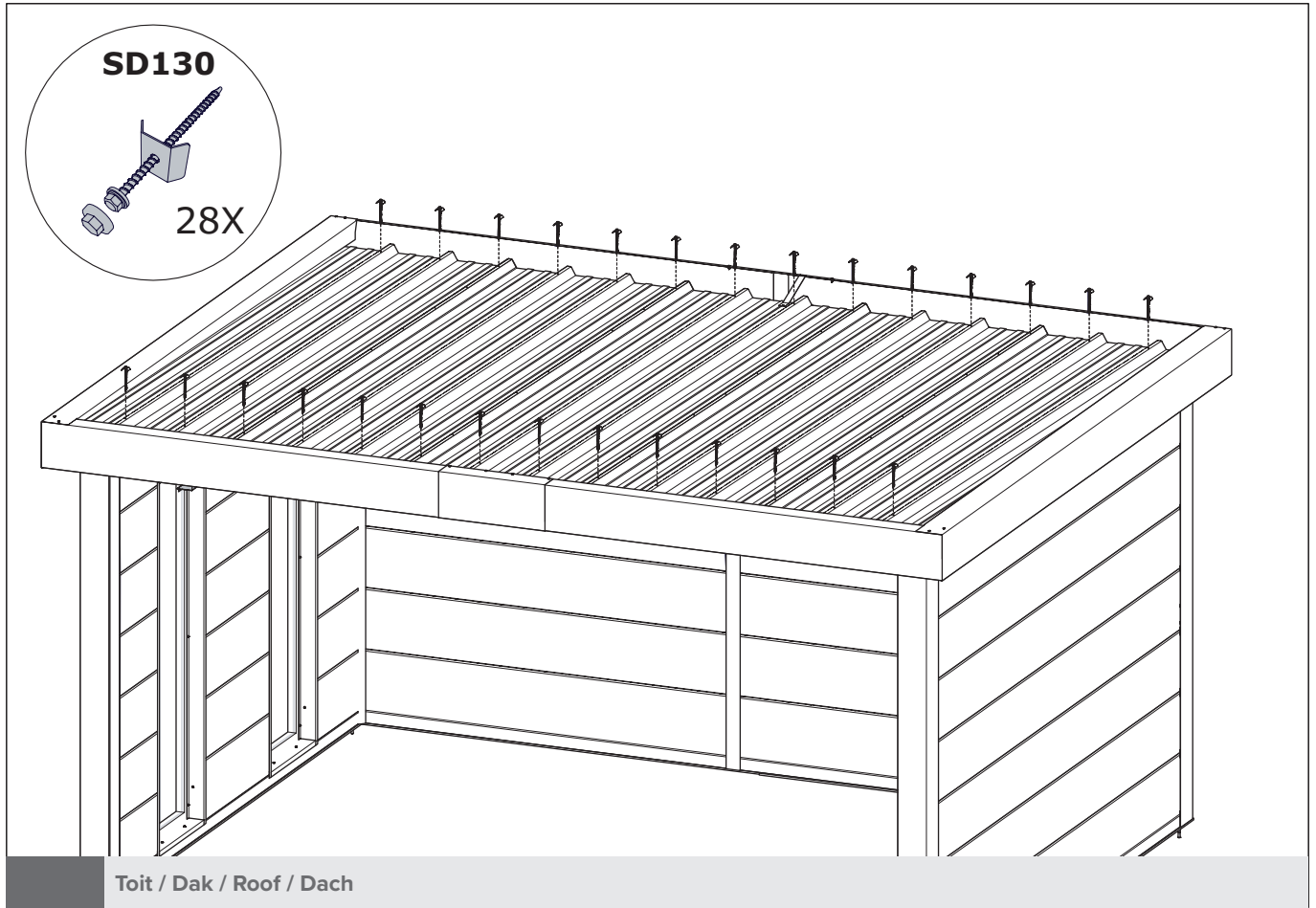

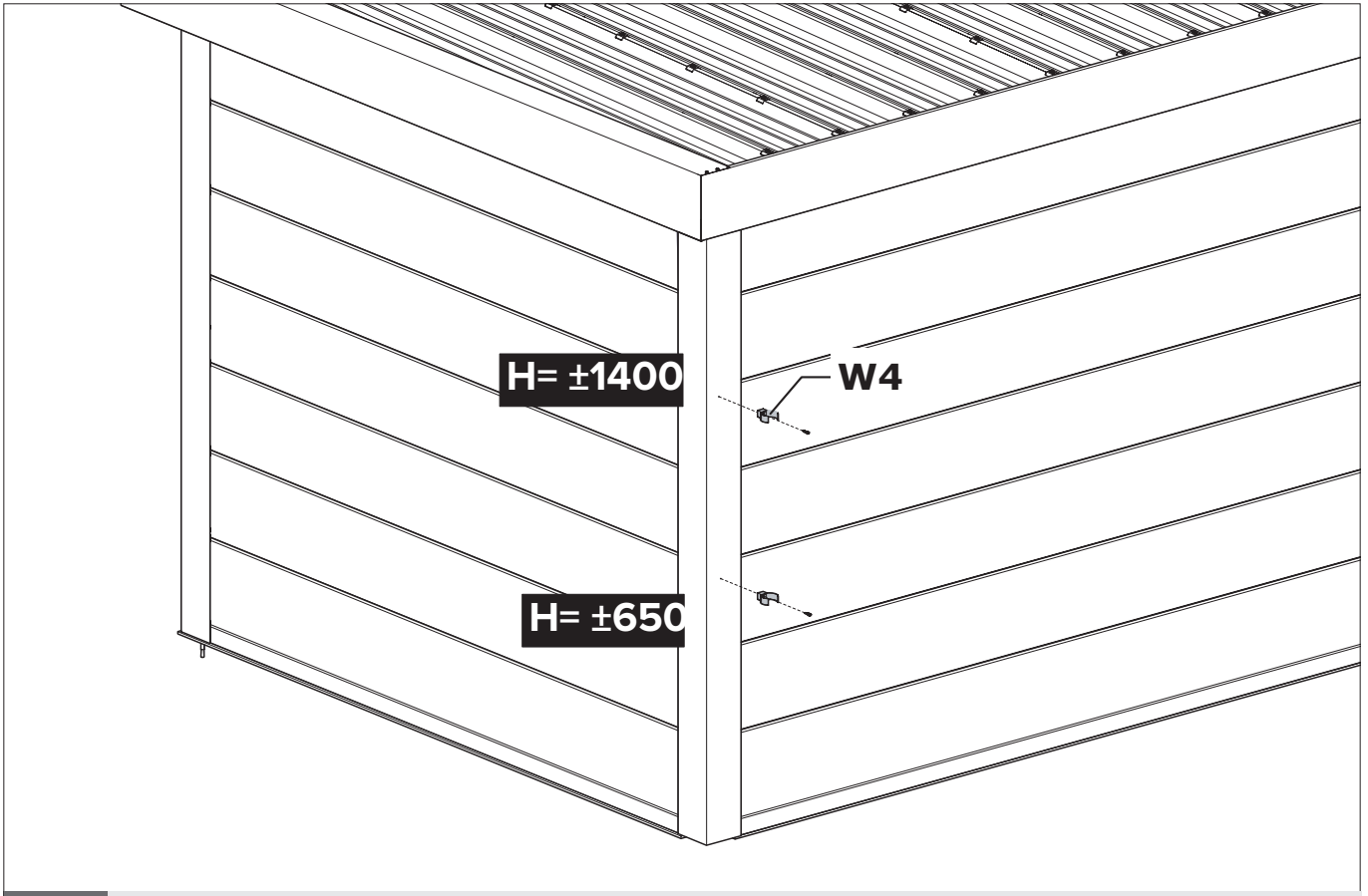

C Paroi / Wand / Wall / Wand

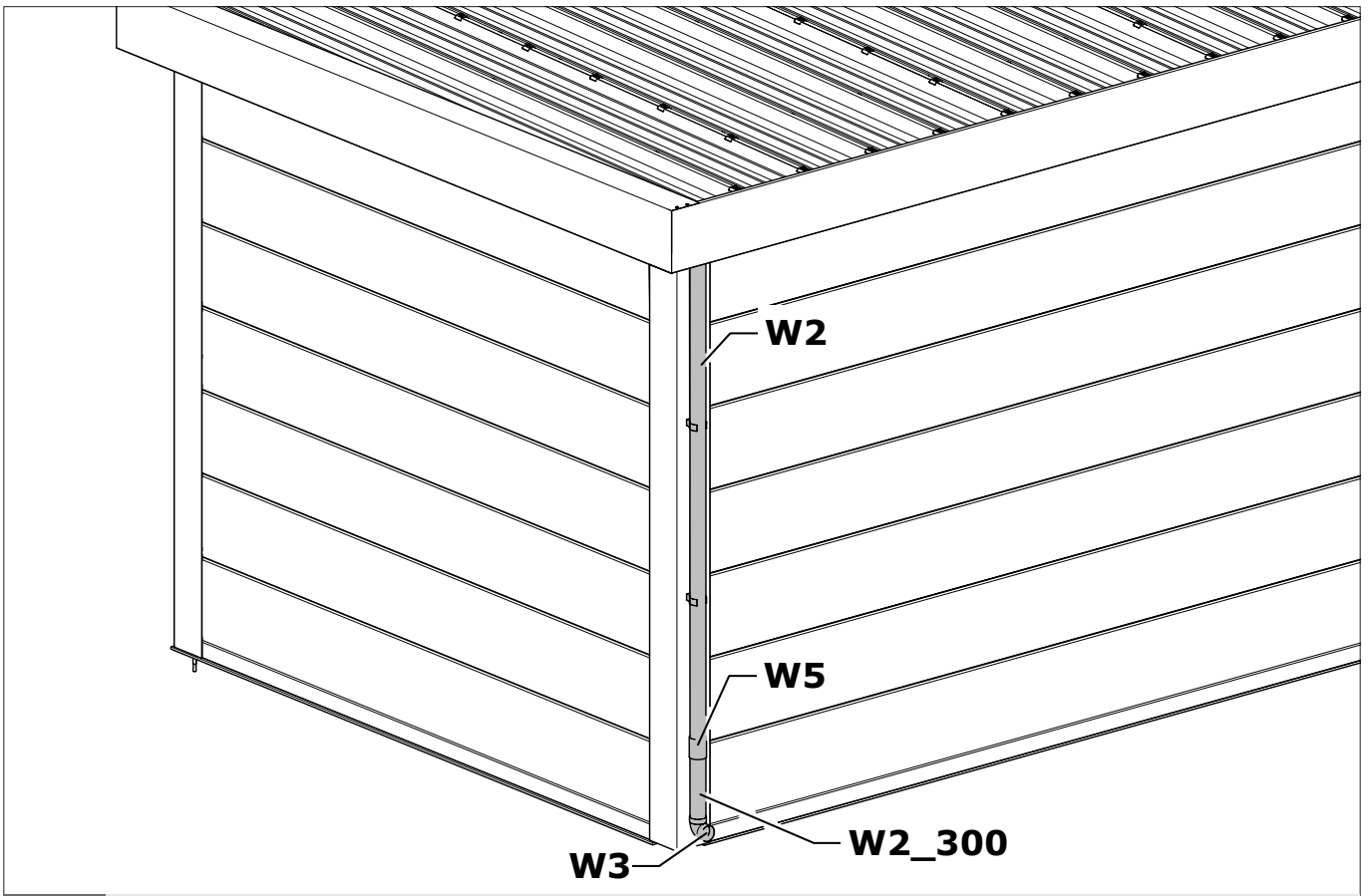

C Paroi / Wand / Wall / Wand

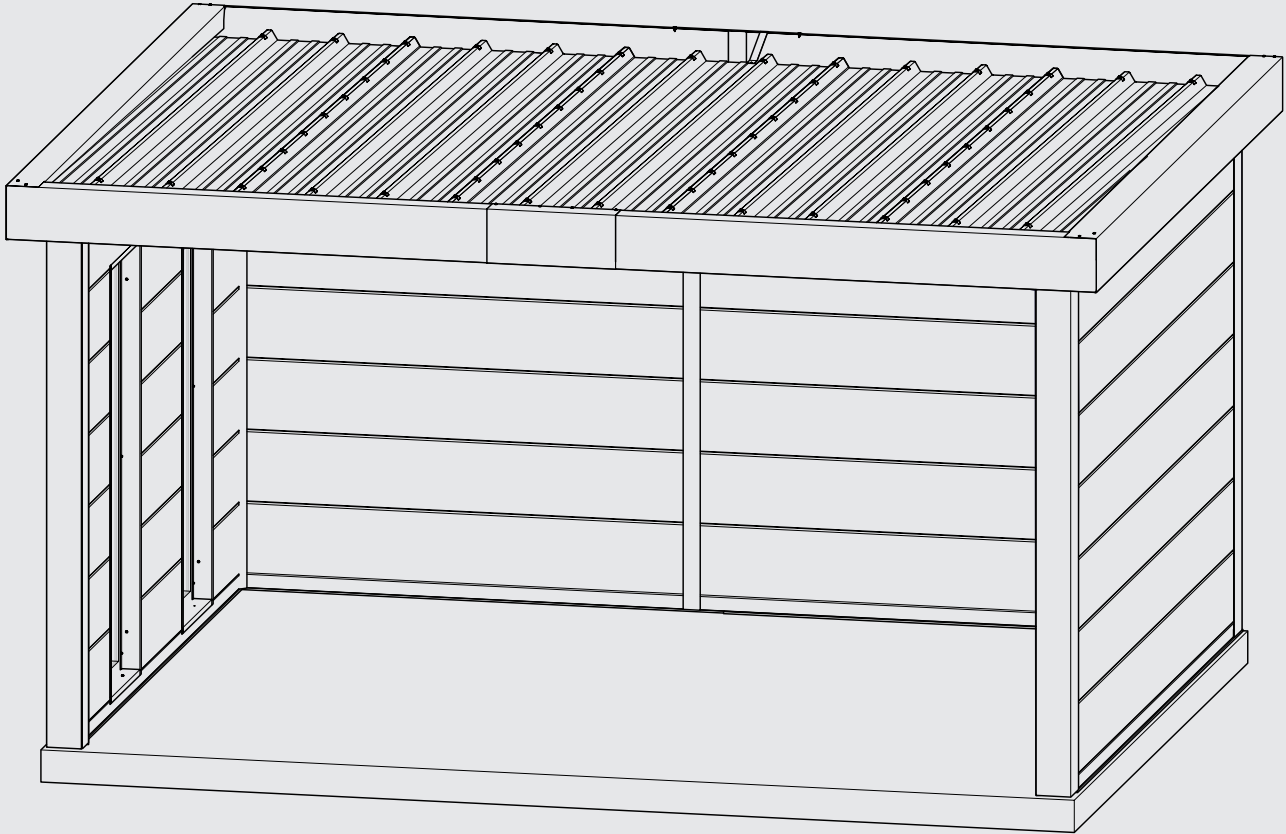

Merci de respecter l'environnement !

Pour une élimination correcte des déchets, il faut trier les différents matériaux conformément à la législation en vigueur. Droits d'auteur Telluria. Tous droits réservés. Aucun élément de la présente publication ne peut être reproduit ou diffusé sans l'autorisation écrite de Telluria. Les informations figurant dans la présente publication sont, pour des raisons techniques et/ou commerciales, sujettes à modification sans avis préalable.

Draag zorg voor het milieu!

Voor een correcte afvalverwijdering moeten de verschillende materialen volgens de toepasselijke regelgeving worden gescheiden. Auteursrechten Telluria. Alle rechten voorbehouden. Niets in deze publicatie mag worden gereproduceerd of verdeeld zonder de schriftelijke toestemming van Telluria. De gegevens in deze publicatie zijn, omwille van technische en/of commerciële redenen, onderhevig aan wijziging zonder voorafgaande kennisgeving.

Protect the environment!

To ensure waste is disposed of correctly, the different materials must be separated according to the applicable regulations. Copyright Telluria. All rights reserved. Nothing in this publication may be reproduced or distributed without written permission from Telluria. The information in this publication is subject to change for technical and/or commercial reasons at any time and without notice.

Achten Sie auf die Umwelt!

Um eine ordnungsgemäße Entsorgung zu gewährleisten, müssen die verschiedenen Materialien entsprechend den geltenden Vorschriften getrennt werden. Copyright Telluria. Alle Rechte vorbehalten. Kein Teil dieser Publikation darf ohne schriftliche Genehmigung von Telluria vervielfältigt oder verbreitet werden. Aus technischen und/oder kommerziellen Gründen können sich die in dieser Publikation enthaltenen Informationen ohne vorherige Ankündigung ändern.

VOUS AVEZ DES QUESTIONS SUR CE PRODUIT:

Mail du service clientèle: CLASSICO-service@telluria.eu

HEEFT U VRAGEN OVER DIT PRODUCT:

Mailadres klantendienst: CLASSICO-service@telluria.eu

DO YOU HAVE QUESTIONS ABOUT THIS PRODUCT:

Customer Service Mail: CLASSICO-service@telluria.eu

SIE HABEN FRAGEN ZU DIESEM PRODUKT:

Kundendienst-Mail: CLASSICO-service@telluria.eu